

SUISEI®

OSAKA JAPAN



SUISEI®
OSAKA JAPAN

CONTENTS

STITCH GUIDE FEET	1 ~ 3
RIGHT COMPENSATING FEET	4 ~ 6
LEFT COMPENSATING FEET	7 ~ 8
DOUBLE COMPENSATING FEET	9
SHIRRING FEET	10 ~ 11
ZIPPER · FASTENER FEET	12
CONCEAL* FEET	13
CORDING FEET	14 ~ 15
STANDARD FEET	16 ~ 18
PIPING FEET	19 ~ 23
TAPE FEET	24 ~ 25
BLANK FEET	26
BINDING FEET	27 ~ 32
EASY FEET	33 ~ 35
FEET FOR KNIT & THIN MATERIALS	36 ~ 37
CORDING FEET (CONCEALED SEAM FEET)	38
HEMMER FEET	39
FELLER FEET	40
FEET for NEEDLE FEED MACHINES	41 ~ 46
FEET for SPECIAL MACHINES	47 ~ 50
TAPE GUIDES	53 ~ 55
STRAIGHT FOLDERS	56 ~ 57
RIGHT ANGLE BIAS BINDERS	58 ~ 60
DOUBLE FOLD BIAS BINDERS	61 ~ 62
SINGLE FOLD BIAS BINDERS	63
HEMMERS	64 ~ 70
BRAID OR TAPE BINDERS	71 ~ 72
FELLERS	73 ~ 75
FOR SPECIAL MACHINES	76
GAUGES · BRACKETS	79 ~ 80
NEEDLE PLATES · FEED DOG	81 ~ 82
SCREWS · SPRINGS	83
BINDING & TAPE REEL STANDS	84 ~ 86
ROLLERS	87
ACCESSORIES	88 ~ 92

PRESSER FEET

SUISEI®
OSAKA JAPAN

STITCH GUIDE FEET

SUISEI
OSAKA JAPAN

Spring Guide Hinged Feet (Right)

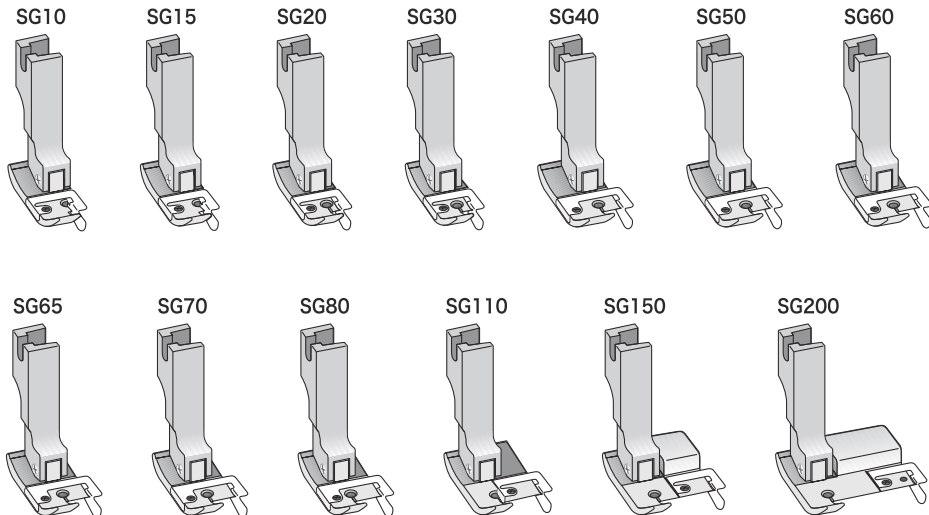

Sizes Details

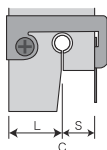

C = Hole in center
S = Stitch margin
L = Left width from needle

Part No.	L	S
SG10	8.2 mm	1.0 mm
SG15	7.7 mm	1.5 mm
SG20	7.2 mm	2.0 mm
SG30	6.2 mm	3.0 mm
SG40	10.0 mm	4.0 mm
SG50	9.0 mm	5.0 mm
SG60	8.0 mm	6.0 mm
SG65	7.5 mm	6.5 mm
SG70	7.0 mm	7.0 mm
SG80	6.0 mm	8.0 mm
SG110	6.0 mm	11.0 mm
SG150	6.0 mm	15.0 mm
SG200	6.0 mm	20.0 mm

Parts Details

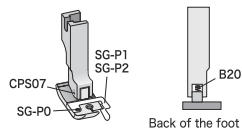

Part No.	Description	Foot No.
B20	Spring for feet	All feet
CPS07	Screw for feet	All feet
SG-P0	Screw (M1,6 x 0,35)	All feet
SG-P1	Spring guide	SG10, SG15, SG20 SG30, SG110 SG150, SG200
SG-P2	Spring guide	SG40, SG50, SG60 SG65, SG70, SG80

NOTE

For straight and curving edges. NO guide part at the rear of the needle hole.

CAUTION

The lower material can be hurt by the spring guide when it is weak and thin.

STITCH GUIDE FEET

SUISEI
OSAKA JAPAN

Spring Guide Hinged Feet (Left)

SG10L

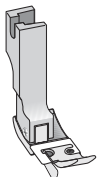

SG15L

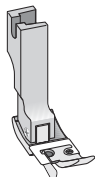

SG20L

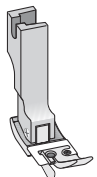

SG30L

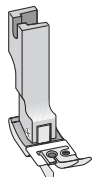

Sizes Details

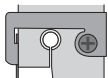

C = Hole in center
R = Right width from needle
S = Stitch margin

Part No.	S	R
SG10L	1.0 mm	8.2 mm
SG15L	1.5 mm	7.7 mm
SG20L	2.0 mm	7.2 mm
SG30L	3.0 mm	6.2 mm

Parts Details

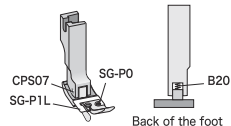

Part No.	Description	Foot No.
B20	Spring for feet	All feet
CPS07	Screw for feet	All feet
SG-P0	Screw (M1.6 × 0.35)	All feet
SG-P1L	pring guide	All feet

The lower material can be hurt by the spring guide when it is weak and thin.

Top Stitch Guide Feet

P10

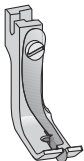

P11



P115



P12



P13



P14



P15



P16



P18



Sizes Details

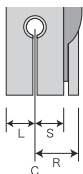

C = Hole in center
L = Left width from needle
S = Stitch margin
R = Right width from needle

Part No.	L	S	R
P10	6.0 mm	0.8 mm	4.0 mm
P11	5.5 mm	1.6 mm	5.5 mm
P115	5.5 mm	2.4 mm	6.0 mm
P12	5.5 mm	3.2 mm	6.5 mm
P13	5.5 mm	4.8 mm	7.5 mm
P14	5.5 mm	6.4 mm	9.5 mm
P15	5.5 mm	8.0 mm	11.0 mm
P16	5.5 mm	9.5 mm	13.0 mm
P18	5.5 mm	12.7 mm	16.0 mm

Parts Details

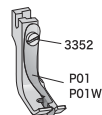

Part No.	Description	Foot No.
3352	Screw (1/2-56)	All feet
P01	Spring guide	P10, P11, P115 P12, P13
P01W	Spring guide	P14, P15, P16, P18

The lower material can be hurt by the spring guide when it is weak and thin.

STITCH GUIDE FEET

SUISEI
OSAKA JAPAN

Hinged Quilter Foot with Right & Left Guides

P723

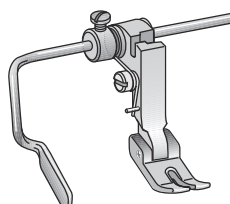
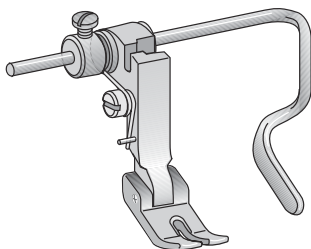

Attach on the Left

Sizes Details

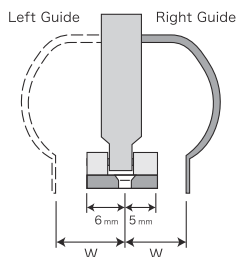

Guides	Stitch margin W
Right Guide	5 ~ 45 mm
Left Guide	6 ~ 45 mm

Parts Details

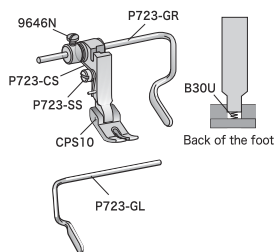

Part No.	Description
B30U	Spring for P723
CPS10	Screw for feet
9646N	Screw (¼-L6)
P723-SS	Shoulder screw
P723-CS	Spring
P723-GR	Right guide
P723-GL	Left guide



RIGHT COMPENSATING FEET

SUISEI
OSAKA JAPAN

Right Compensating Feet

SR10

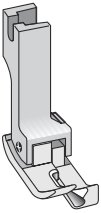

SR15

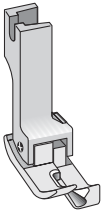

SR20

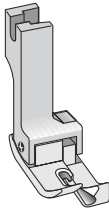

SR25

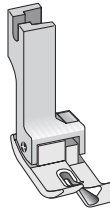

SR30

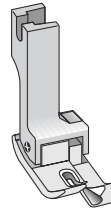

SR40

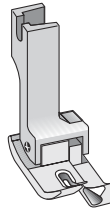

SR50

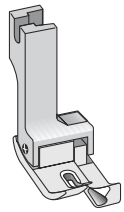

SR60

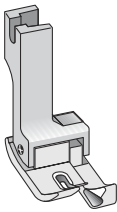

SR65

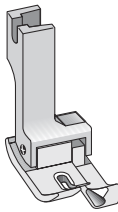

SR70

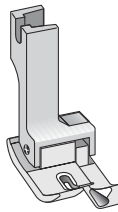

SR80

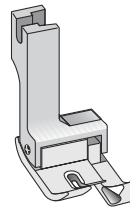

SR100

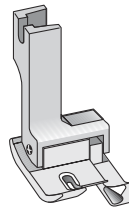

Sizes Details

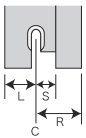
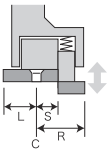

C = Hole in center
L = Left width from needle
S = Stitch margin
R = Right width from needle

Part No.	L	S	R
SR10	5.75 mm	1.0 mm	5.75 mm
SR15	5.25 mm	1.5 mm	6.25 mm
SR20	6.25 mm	2.0 mm	6.75 mm
SR25	6.00 mm	2.5 mm	7.25 mm
SR30	6.00 mm	3.0 mm	7.75 mm
SR40	6.00 mm	4.0 mm	8.75 mm
SR50	6.25 mm	5.0 mm	9.75 mm
SR60	6.00 mm	6.0 mm	10.75 mm
SR65	6.00 mm	6.5 mm	11.25 mm
SR70	6.00 mm	7.0 mm	11.75 mm
SR80	6.25 mm	8.0 mm	12.75 mm
SR100	6.00 mm	10.0 mm	14.75 mm

Parts Details

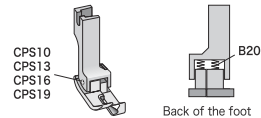

Part No.	Description	Foot No.
B20	Spring for feet	All feet
CPS10	Screw for feet	SR10, SR15
CPS13	Screw for feet	SR20, SR25 SR30, SR40
CPS16	Screw for feet	SR50, SR60 SR65, SR70
CPS19	Screw for feet	SR80, SR100



RIGHT COMPENSATING FEET

SUISEI
OSAKA JAPAN

Right Compensating Foot Narrow Type

SR10N

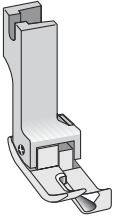

SR15N

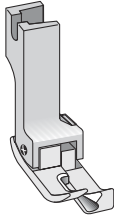

Sizes Details

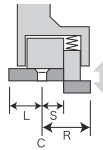

C = Hole in center
L = Left width from needle
S = Stitch margin
R = Right width from needle

Part No.	L	S	R
SR10N	4,75 mm	1,0 mm	5,75 mm
SR15N	4,25 mm	1,5 mm	6,25 mm

Parts Details

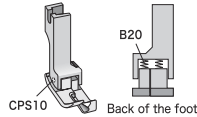

Part No.	Description	Foot No.
B20	Spring for feet	All feet
CPS10	Screw for feet	All feet

Right Compensating Foot Extra Short

SRC10

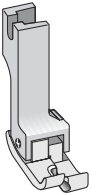

SRC15

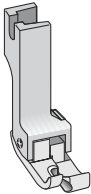

SRC20

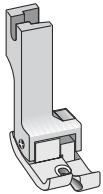

SRC30

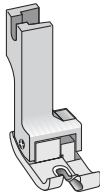

Sizes Details

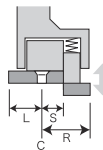

C = Hole in center
L = Left width from needle
S = Stitch margin
R = Right width from needle

Part No.	L	S	R
SRC10	4,75 mm	1,0 mm	5,75 mm
SRC15	4,25 mm	1,5 mm	6,25 mm
SRC20	6,25 mm	2,0 mm	6,75 mm
SRC30	5,25 mm	3,0 mm	7,75 mm

NOTE

These feet are appropriate for sewing small parts as out pockets or labels. Because it is 4 millimeters the toe side from the needle and 7 millimeters shorter than regular compensating feet.

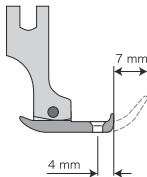

Parts Details

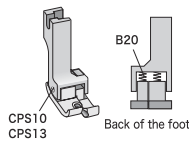

Part No.	Description	Foot No.
B20	Spring for feet	All feet
CPS10	Screw for feet	SRC10 SRC15
CPS13	Screw for feet	SRC20 SRC30



Right Compensating Feet for Knit & Thin materials

SR10KZ

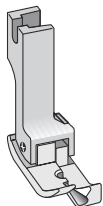

SR15KZ

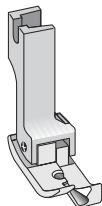

SR20KZ

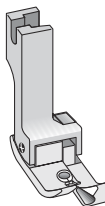

SR25KZ

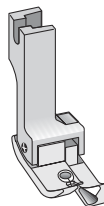

SR30KZ

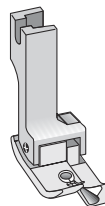

SR40KZ

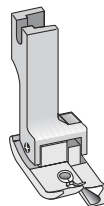

SR50KZ

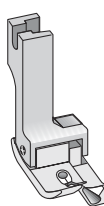

SR60KZ

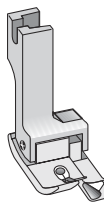

SR65KZ

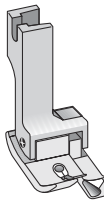

SR10NKZ

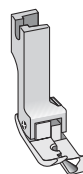

SR15NKZ

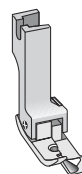

Narrow type

Sizes Details

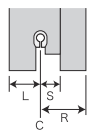
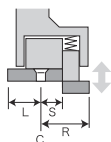

C = Hole in center
L = Left width from needle
S = Stitch margin
R = Right width from needle

Part No.	L	S	R
SR10KZ	5.75 mm	1.0 mm	5.75 mm
SR15KZ	5.25 mm	1.5 mm	6.25 mm
SR20KZ	6.25 mm	2.0 mm	6.75 mm
SR25KZ	6.00 mm	2.5 mm	7.25 mm
SR30KZ	6.00 mm	3.0 mm	7.75 mm
SR40KZ	6.00 mm	4.0 mm	8.75 mm
SR50KZ	6.25 mm	5.0 mm	9.75 mm
SR60KZ	6.00 mm	6.0 mm	10.75 mm
SR65KZ	6.00 mm	6.5 mm	11.25 mm
SR10NKZ	4.75 mm	1.0 mm	5.75 mm
SR15NKZ	4.25 mm	1.5 mm	6.25 mm

Parts Details

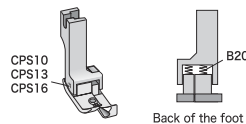

Part No.	Description	Foot No.
B20	Spring for feet	All feet
CPS10	Screw for feet	SR10KZ, SR15KZ SR10NKZ, SR15NKZ
CPS13	Screw for feet	SR20KZ, SR25KZ SR30KZ, SR40KZ
CPS16	Screw for feet	SR50KZ, SR60KZ SR65KZ

Needle Hole Type

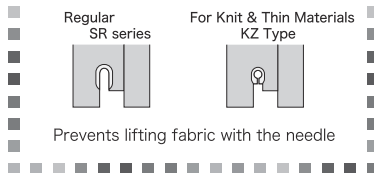

LEFT COMPENSATING FEET

SUISEI
OSAKA JAPAN

Left Compensating Foot

SL10

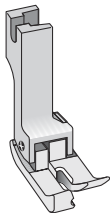

SL15

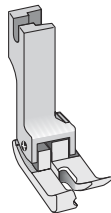

SL20

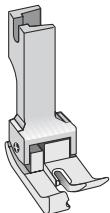

SL25

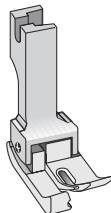

SL30

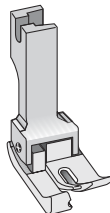

SL40

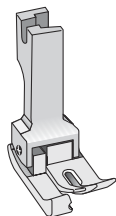

SL50

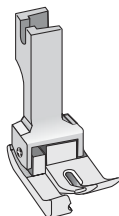

SL60

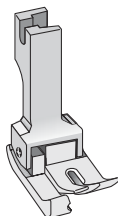

CL70

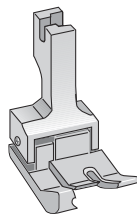

CL80

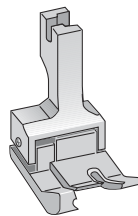

Sizes Details

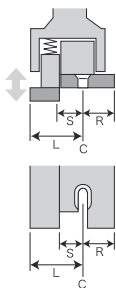

C = Hole in center
L = Left width from needle
S = Stitch margin
R = Right width from needle

Part No.	L	S	R
SL10	5.75 mm	1.0 mm	5.75 mm
SL15	6.25 mm	1.5 mm	5.25 mm
SL20	6.75 mm	2.0 mm	6.25 mm
SL25	7.25 mm	2.5 mm	6.00 mm
SL30	7.75 mm	3.0 mm	6.00 mm
SL40	8.75 mm	4.0 mm	6.00 mm
SL50	9.75 mm	5.0 mm	6.25 mm
SL60	10.75 mm	6.0 mm	6.00 mm
CL70	12.70 mm	7.0 mm	6.20 mm
CL80	13.60 mm	8.0 mm	5.30 mm

Parts Details

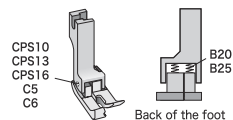

Part No.	Description	Foot No.
B20	Spring for feet	SL feet
B25	Spring for feet	CL feet
CPS10	Screw for feet	SL10, SL15
CPS13	Screw for feet	SL20, SL25 SL30, SL40
CPS16	Screw for feet	SL50, SL60
C5	Screw for feet	CL70
C6	Screw for feet	CL80

LEFT COMPENSATING FEET

SUISEI
OSAKA JAPAN

Left Compensating Foot Narrow Type

SL10N

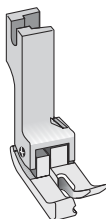

SL15N

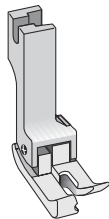

Sizes Details

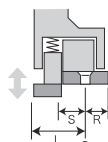

C = Hole in center
L = Left width from needle
S = Stitch margin
R = Right width from needle

Part No.	L	S	R
SL10N	5.75 mm	1.0 mm	4.75 mm
SL15N	6.25 mm	1.5 mm	4.25 mm

Parts Details

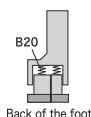
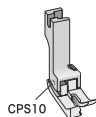

Part No.	Description	Foot No.
B20	Spring for feet	All feet
CPS10	Screw for feet	All feet

Left Compensating Foot Extra Short

SLC10

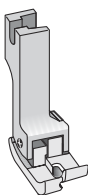

SLC15

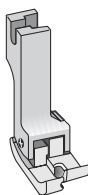

SLC20

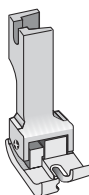

SLC30

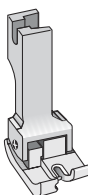

Parts Details

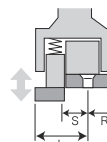

C = Hole in center
L = Left width from needle
S = Stitch margin
R = Right width from needle

Part No.	L	S	R
SLC10	5.75 mm	1.0 mm	4.75 mm
SLC15	6.25 mm	1.5 mm	4.25 mm
SLC20	6.75 mm	2.0 mm	6.25 mm
SLC30	7.75 mm	3.0 mm	5.25 mm

NOTE

These feet are appropriate for sewing small parts as out pockets or labels. Because it is 4 millimeters the toe side from the needle and 7 millimeters shorter than regular compensating feet.

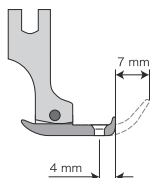

Parts Details

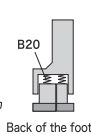
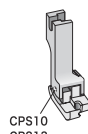

Part No.	Description	Foot No.
B20	Spring for feet	All feet
CPS10	Screw for feet	SLC10 SLC15
CPS13	Screw for feet	SLC20 SLC30

DOUBLE COMPENSATING FEET

SUISEI
OSAKA JAPAN

Double Compensating Feet

SD10

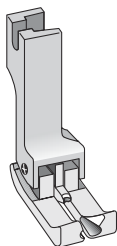

SD15

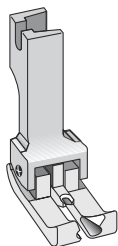

SD20

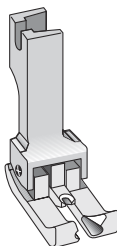

SD25

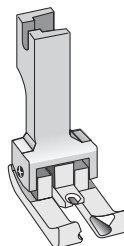

SD30

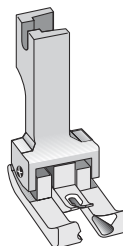

Sizes Details

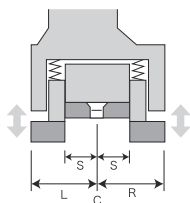

C = Hole in center
L = Left width from needle
S = Stitch margin
R = Right width from needle

Part No.	L	S	R
SD10	5.75 mm	1.0 mm	5.75 mm
SD15	6.25 mm	1.5 mm	6.25 mm
SD20	6.75 mm	2.0 mm	6.75 mm
SD25	7.25 mm	2.5 mm	7.25 mm
SD30	7.75 mm	3.0 mm	7.75 mm

Parts Details

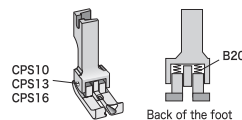

Part No.	Description	Foot No.
B20	Spring for feet	All feet
CPS10	Screw for feet	SD10
CPS13	Screw for feet	SD15, SD20
CPS16	Screw for feet	SD25, SD30

Adjustable Shirring Foot (Gather Hybrid Foot)

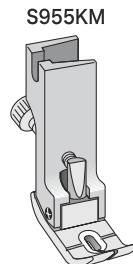
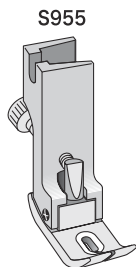

Sizes Details

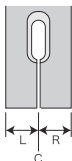

C = Hole in center
L = Left width from needle
R = Right width from needle

Part No.	L	R
S955	5,25 mm	5,25 mm
S955KM	5,25 mm	5,25 mm

Parts Details

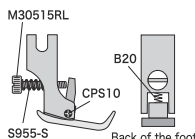

Part No.	Description	Foot No.
B20	Spring for feet	All feet
CPS10	Screw for feet	All feet
M30515RL	screw (M3 - L15)	All feet
S955-S	Spring	All feet

NOTE

For bottom ply of pocket flap lining.

⚠ CAUTION

- Over turning of the adjust screw causes damages of pin.
- Feeding scratches can happen when the material is weak and thin.

SHIRRING FEET

SUISEI
OSAKA JAPAN

Top Ply Joining Shirring Foot

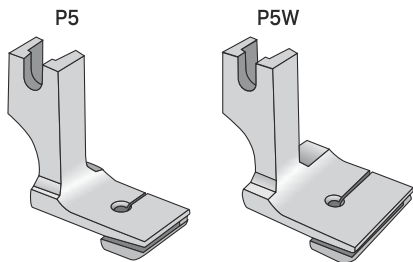

Sizes Details

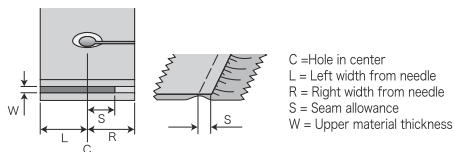

Part No.	L	R	S	W
P5	7.0 mm	7.0 mm	4.5 mm	1.0 mm
P5W	9.0 mm	13.0 mm	10.0 mm	1.0 mm

⚠ CAUTION

Feeding scratches can happen when the material is weak and thin.

Regular Shirring Feet

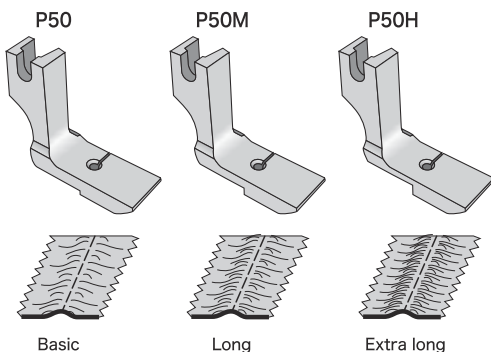

Sizes Details

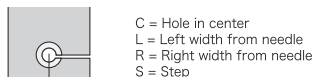

Part No.	L	R	S
P50	6.0 mm	6.0 mm	1.5 mm
P50M	6.0 mm	6.0 mm	2.0 mm
P50H	6.0 mm	6.0 mm	2.8 mm

⚠ CAUTION

Feeding scratches can happen when the material is weak and thin.

ZIPPER • FASTENER FEET

SUISEI
OSAKA JAPAN

Hinged Zipper Feet

S2525

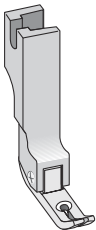

S3030

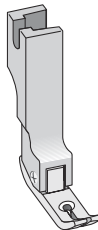

SP360

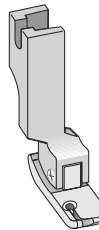

SP361

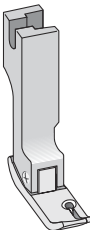

Sizes Details

C = Hole in center
L = Left width from needle
R = Right width from needle



Part No.	L	R
S2525	2,5 mm	2,5 mm
S3030	3,0 mm	3,0 mm
SP360	2,0 mm	6,0 mm
SP361	6,0 mm	2,0 mm

Parts Details

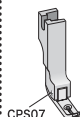

CPS07

Back of the foot

Part No.	Description	Foot No.
B20	Spring for foot	All feet
CPS07	Screw for foot	All feet

Solid Zipper Feet

P3

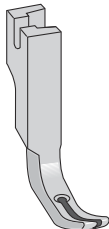

P3C

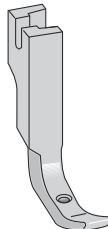

P3CS

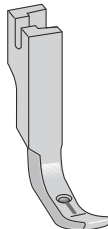

Sizes Details

C = Hole in center
L = Left width from needle
R = Right width from needle



Part No.	L	R
P3	2,5 mm	2,5 mm
P3C	2,5 mm	2,5 mm
P3CS	2,5 mm	2,5 mm

Conceal® Feet

SDK15ND

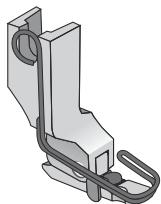

SDK18ND

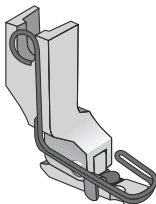

SDK-NGD

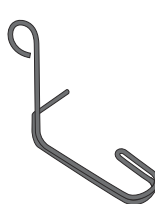

Sizes Details

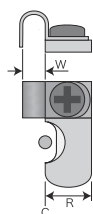

C = Hole in center
R = Right width from needle
W = Tunnel width

Part No.	R	W	Fastener Type
SDK15ND	5.0 mm	1.5 mm	2CC
SDK18ND	5.0 mm	1.8 mm	3CC

NOTE

- Compactly designed for easy using.
- Enable to skip the step of ironing.

Parts Details

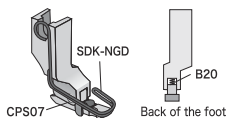

Part No.	Description	Foot No.
B20	Spring for foot	All feet
CPS07	Screw for foot	All feet
SDK-NGD	Finger guard	All feet

How to set finger guard

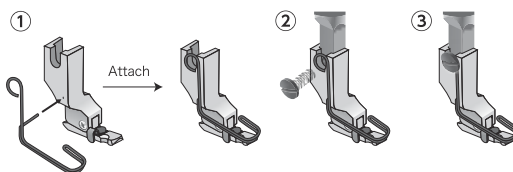

⚠ CAUTION

This product is extra compact compare with usual foot.
It might cause finger damage by accident.
Please use special finger guard for Conceal foot for your safety.

CORDING FEET

SUISEI
OSAKA JAPAN

Hinged Left Cording Feet

SP36LN

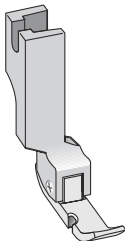

SP36L

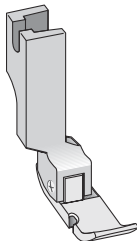

Sizes Details

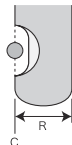

C = Hole in center
R = Right width from needle

Part No.	R
SP36LN	5,0 mm
SP36L	8,0 mm

Parts Details

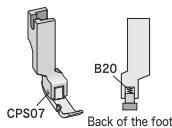

Part No.	Description	Foot No.
B20	Spring for feet	All feet
CPS07	Screw for feet	All feet

Solid Left Cording Feet

P301N

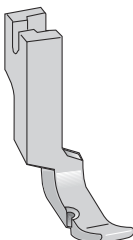

P301

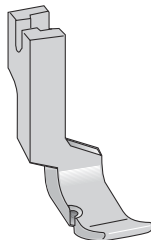

Sizes Details

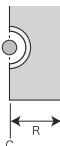

C = Hole in center
R = right width from needle

Part No.	R
P301N	5,0 mm
P301	8,0 mm

Hinged Right Cording Feet

SP36N

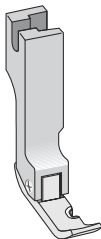

SP36

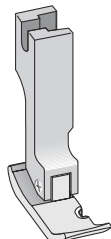

Sizes Details



C = Hole in center
L = Left width from needle

Part No.	L
SP36N	5.0 mm
SP36	8.0 mm

Parts Details

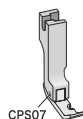

CPS07

B20

Back of the foot

Part No.	Description	Foot No.
B20	Spring for feet	All feet
CPS07	Screw for feet	All feet

Solid Right Cording Feet

P311N

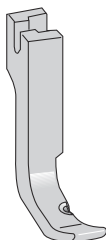

P31

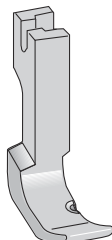

Sizes Details

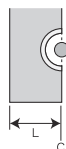

C = Hole in center
L = Left width from needle

Part No.	L
P311N	5.0 mm
P31	8.0 mm

STANDARD FEET

Hinged Left Narrow Feet

S1060

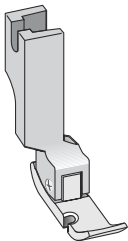

S1560

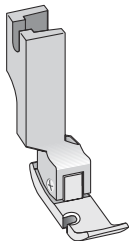

SP360

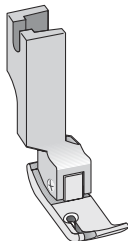

Sizes Details



C = Hole in center
L = Left width from needle
R = Right width from needle

Part No.	L	R
S1060	1.0 mm	6.0 mm
S1560	1.5 mm	6.0 mm
SP360	2.0 mm	6.0 mm

Parts Details

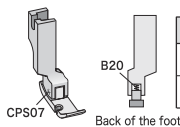

Part No.	Description	Foot No.
B20	Spring for feet	All feet
CPS07	Screw for feet	All feet

Hinged Right Narrow Feet

S6010

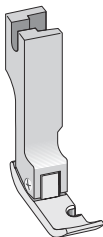

S6015

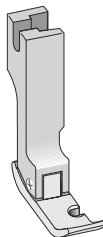

SP361

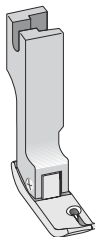

Sizes Details

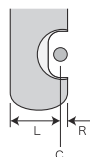

C = Hole in center
L = Left width from needle
R = Right width from needle

Part No.	L	R
S6010	6.0 mm	1.0 mm
S6015	6.0 mm	1.5 mm
SP361	6.0 mm	2.0 mm

Parts Details

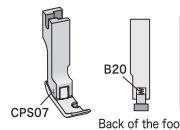

Part No.	Description	Foot No.
B20	Spring for feet	All feet
CPS07	Screw for feet	All feet

STANDARD FEET

SUISEI
OSAKA JAPAN

Hinged Double Toe Even Feet

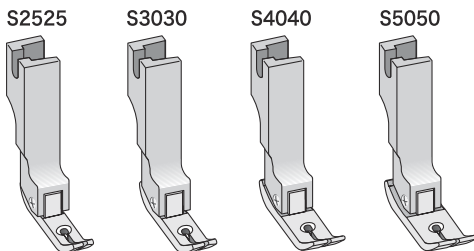

Sizes Details



C = Hole in center
L = Left width from needle
R = Right width from needle

Part No.	L	R
S2525	2.5 mm	2.5 mm
S3030	3.0 mm	3.0 mm
S4040	4.0 mm	4.0 mm
S5050	5.0 mm	5.0 mm

Parts Details

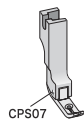

B20

Back of the foot

Part No.	Description	Foot No.
B20	Spring for feet	All feet
CPS07	Screw for feet	All feet

Hinged Turned Up Front Feet

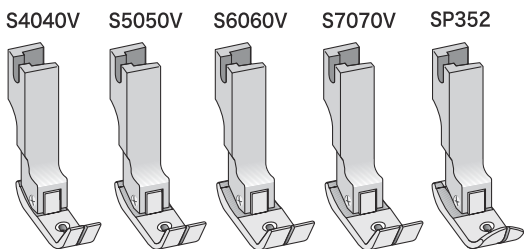

Sizes Details

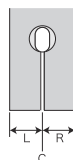

C = Hole in center
L = Left width from needle
R = Right width from needle

Part No.	L	R
S4040V	4.0 mm	4.0 mm
S5050V	5.0 mm	5.0 mm
S6060V	6.0 mm	6.0 mm
S7070V	7.0 mm	7.0 mm
SP352	6.5 mm	4.5 mm

Parts Details

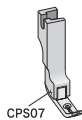

B20

Back of the foot

Part No.	Description	Foot No.
B20	Spring for feet	All feet
CPS07	Screw for feet	All feet

Hinged Standard Feet

SP58N

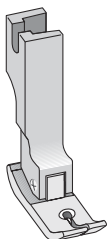

SP351

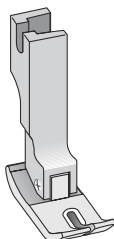

SP351KZ

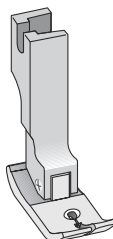

S6565

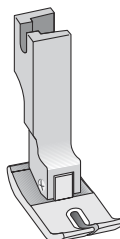

SP127

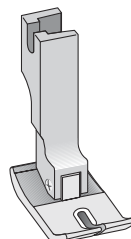

Sizes Details

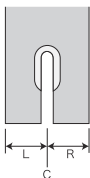

C = Hole in center
L = Left width from needle
R = Right width from needle

Part No.	L	R
SP58N	5.0 mm	4.0 mm
SP351	6.0 mm	5.0 mm
SP351KZ	6.0 mm	5.0 mm
S6565	6.5 mm	6.5 mm
SP127	7.5 mm	7.0 mm

Parts Details

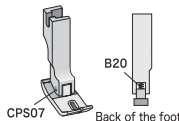

Part No.	Description	Foot No.
B20	Spring for feet	All feet
CPS07	Screw for feet	All feet

NOTE

SP351KZ



Prevents lifting fabric with the needle

PIPING FEET

SUISEI
OSAKA JAPAN

Hinged Left Piping Feet

S69LH-30

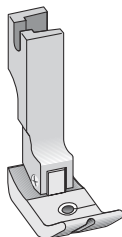

S69LH-50

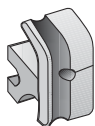
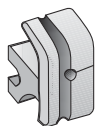
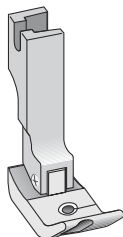

Sizes Details

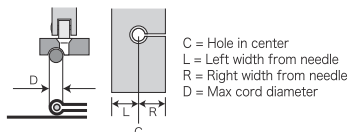

Part No.	L	R	D
S69LH-30	6.0 mm	6.0 mm	3.0 mm
S69LH-50	6.0 mm	6.0 mm	5.0 mm

Parts Details

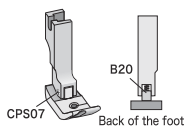

Part No.	Description	Foot No.
B20	Spring for feet	All feet
CPS07	Screw for feet	All feet

Hinged Right Piping Feet

S69RH-30

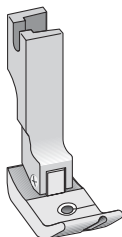

S69RH-50

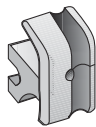
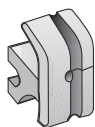
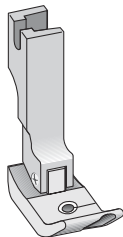

Sizes Details

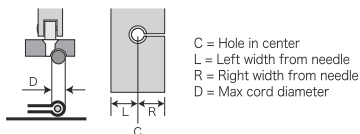

Part No.	L	R	D
S69RH-30	6.0 mm	6.0 mm	3.0 mm
S69RH-50	6.0 mm	6.0 mm	5.0 mm

Parts Details

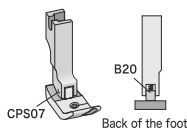

Part No.	Description	Foot No.
B20	Spring for feet	All feet
CPS07	Screw for feet	All feet

PIPING FEET

SUISEI
OSAKA JAPAN

Solid Left Piping Feet

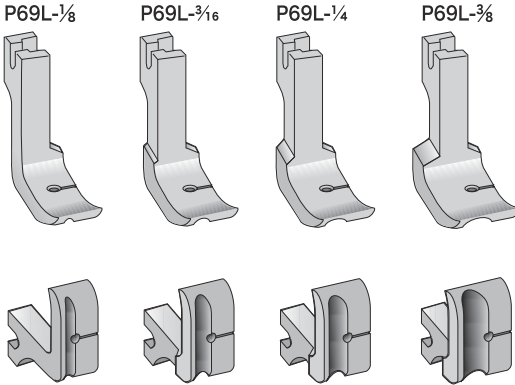

Sizes Details

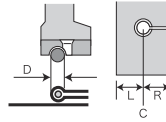

C = Hole in center
L = Left width from needle
R = Right width from needle
D = Max cord diameter

Part No.	L	R	D
P69L- $\frac{1}{8}$	6.0 mm	6.0 mm	3.2 mm
P69L- $\frac{3}{16}$	7.0 mm	7.0 mm	4.8 mm
P69L- $\frac{1}{4}$	7.5 mm	7.5 mm	6.4 mm
P69L- $\frac{3}{8}$	12.0 mm	6.0 mm	9.5 mm

Solid Right Piping Feet

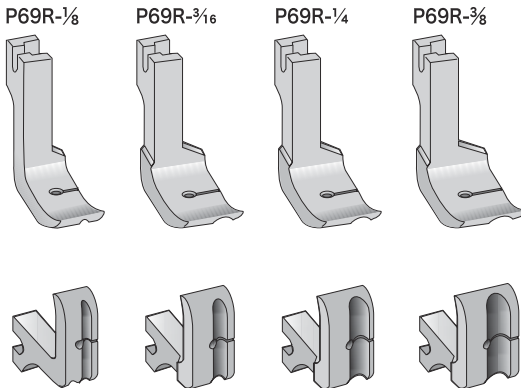

Sizes Details

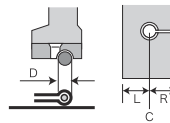

C = Hole in center
L = Left width from needle
R = Right width from needle
D = Max cord diameter

Part No.	L	R	D
P69R- $\frac{1}{8}$	6.0 mm	6.0 mm	3.2 mm
P69R- $\frac{3}{16}$	7.0 mm	7.0 mm	4.8 mm
P69R- $\frac{1}{4}$	7.5 mm	7.5 mm	6.4 mm
P69R- $\frac{3}{8}$	6.0 mm	12.0 mm	9.5 mm

PIPING FEET

SUISEI
OSAKA JAPAN

Solid Double Piping Feet

P69D-1/8

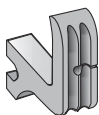
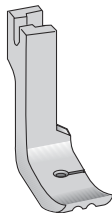

P69D-3/16

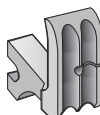
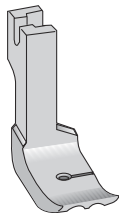

P69D-1/4

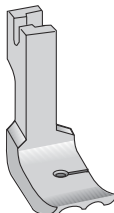

Sizes Details

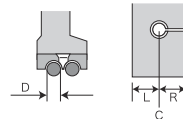

C = Hole in center
L = Left width from needle
R = Right width from needle
D = Max cord diameter

Part No.	L	R	D
P69D-1/8	6.0 mm	6.0 mm	3.2 mm
P69D-3/16	7.0 mm	7.0 mm	4.8 mm
P69D-1/4	7.5 mm	7.5 mm	6.4 mm

Special Piping Feet for A20

P37

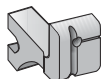
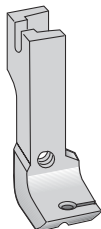

P37M

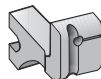
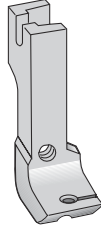

P37W

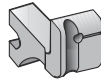
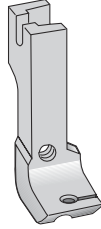

Sizes Details

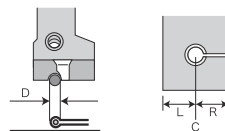

C = Hole in center
L = Left width from needle
R = Right width from needle
D = Max cord diameter

Part No.	L	R	D
P37	6.0 mm	6.0 mm	2.0 mm
P37M	6.0 mm	6.0 mm	3.0 mm
P37W	6.0 mm	6.0 mm	4.0 mm

PIPING FEET

SUISEI
OSAKA JAPAN

Bias Cord Piping Foot

A20-18

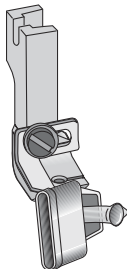

P37

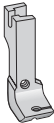

P37M

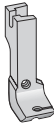

P37W

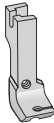

Regular set is fixed P37M.
If not appropriate to the finish, please change to P37 or P37W feet are also available at extra cost. (Referred on Page 21)

Referred below table parts number of each tape size.

Sizes Details

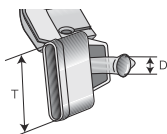

T = Tape size
D = Max cord diameter

Part No.	T	D
A20-18	18 mm	3.0 mm
A20-20	20 mm	3.0 mm
A20-22	22 mm	3.0 mm
A20-24	24 mm	3.5 mm
A20-26	26 mm	3.5 mm
A20-28	28 mm	3.5 mm

Parts Details

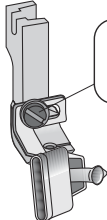

A18-PA

Washer



Spring Washer



Screw



Part No.	Description
A18-PA	Screw & washer set

With cord



Without cord



PIPING FEET

SUISEI
OSAKA JAPAN

Left Piping Easy Feet

STP20L

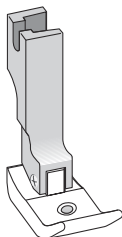

STP30L

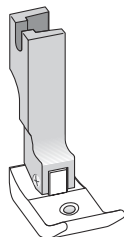

STP35L

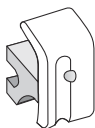
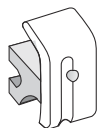
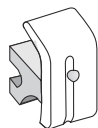
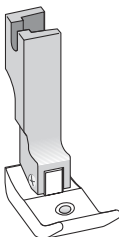

Sizes Details

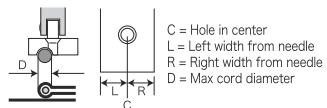

Part No.	L	R	D
STP20L	6.5 mm	6.5 mm	2.0 mm
STP30L	6.5 mm	6.5 mm	3.0 mm
STP35L	6.5 mm	6.5 mm	3.5 mm

Parts Details

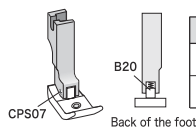

Part No.	Description	Foot No.
B20	Spring for feet	All feet
CPS07	Screw for feet	All feet

Right Piping Easy Feet

STP20R

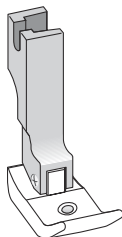

STP30R

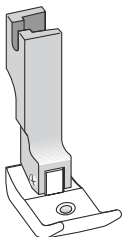

STP35R

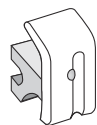
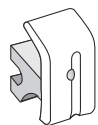
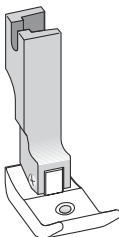

Sizes Details

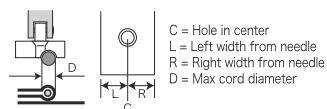

Part No.	L	R	D
STP20R	6.5 mm	6.5 mm	2.0 mm
STP30R	6.5 mm	6.5 mm	3.0 mm
STP35R	6.5 mm	6.5 mm	3.5 mm

Parts Details

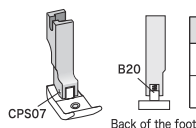

Part No.	Description	Foot No.
B20	Spring for feet	All feet
CPS07	Screw for feet	All feet

Adjustable Tape Feet

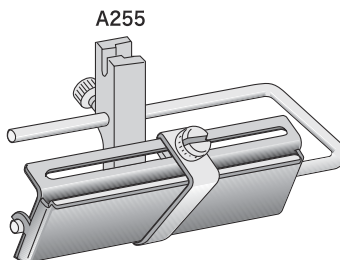
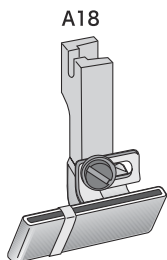

Sizes Details

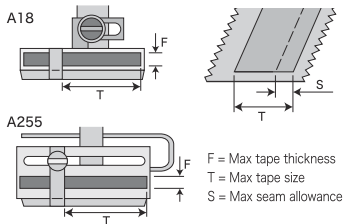

Part No.	F	T	S
A18	1.0 mm	28 mm	12 mm
A255	1.5 mm	53 mm	52 mm

A18 Parts Details

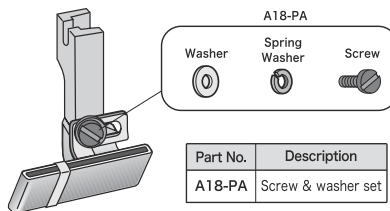

A255 Parts Details

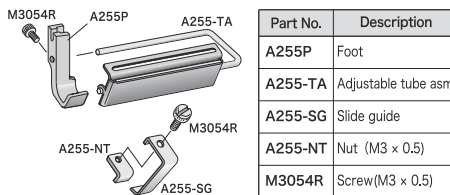

NOTE

This foot can be used at right or left side by adjustable guide position.

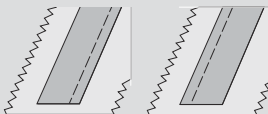

● TAPE FEET

SUISEI
OSAKA JAPAN

Bias Loop Piping Foot

A21-3

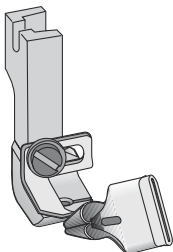

Referred right table parts number of each tape size.

Sizes Details

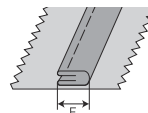

F = Finished size
T = Bias tape size

Part No.	T	F
A21-3	12 mm	3.0 mm
A21-4	16 mm	4.0 mm
A21-5	20 mm	5.0 mm
A21-6.5	25 mm	6.5 mm

Parts Details

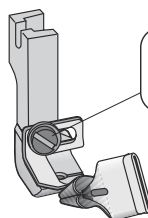

A18-PA

Washer



Spring Washer



Screw

Part No.	Description
A18-PA	Screw & washer set

Foot for A18 or A21

P39

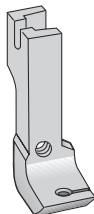

Sizes Details

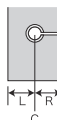

C = Hole in center
L = Left width from needle
R = Right width from needle

Part No.	L	R
P39	6.0 mm	6.0 mm



Solid Blank Feet

SP60

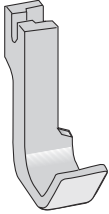

SP62

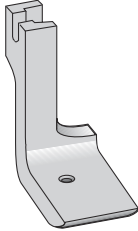

SP63

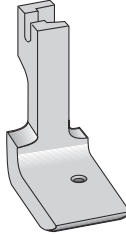

SP64

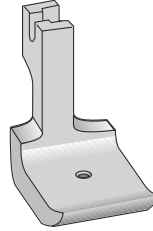

SP65

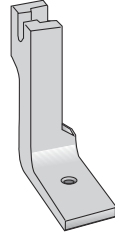

NOTE

These feet are not hardened, and can be easily cut away as you like.

Sizes Details

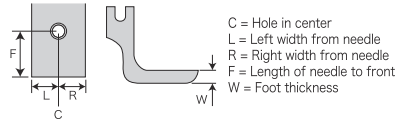

Part No.	L	R	F	W
SP60	6,0 mm	6,0 mm	—	3,0 mm
SP62	6,0 mm	11,0 mm	15,0 mm	6,0 mm
SP63	11,0 mm	6,0 mm	15,0 mm	6,0 mm
SP64	10,5 mm	10,5 mm	14,0 mm	6,0 mm
SP65	6,3 mm	6,3 mm	15,0 mm	3,0 mm

F size of SP60 is not indicated by type of turned up front.

BINDING FEET

SUISEI
OSAKA JAPAN

Hinged Binding Feet

SA40

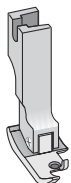

SA45

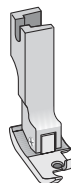

SA55

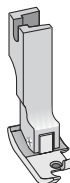

SA65

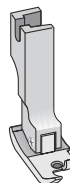

SA75

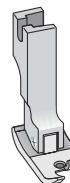

SA85



SA95



SA105

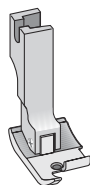

SA130

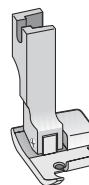

SA140

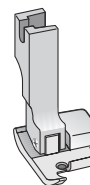

SA150

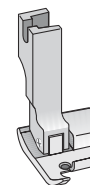

SA200

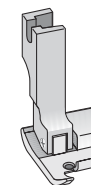

SA250

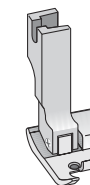

Sizes Details

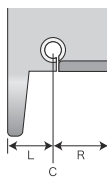

C = Hole in center
L = Left width from needle
R = Right width from needle

Part No.	L	R
SA40	6.0 mm	2.5 mm
SA45	6.0 mm	3.0 mm
SA55	6.0 mm	4.0 mm
SA65	6.0 mm	5.0 mm
SA75	6.0 mm	6.0 mm
SA85	6.0 mm	7.0 mm
SA95	6.0 mm	8.0 mm
SA105	6.0 mm	9.0 mm
SA130	6.0 mm	11.0 mm
SA140	6.0 mm	12.0 mm
SA150	6.0 mm	13.0 mm
SA200	6.0 mm	18.0 mm
SA250	6.0 mm	22.0 mm

Parts Details

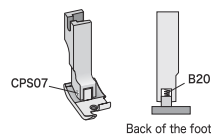

Part No.	Description	Foot No.
B20	Spring for feet	All feet
CPS07	Screw for feet	All feet

NOTE

Referred on page 51 for applicable each binder.

BINDING FEET

SUISEI
 OSAKA JAPAN

Compensating Binding Feet

SC40

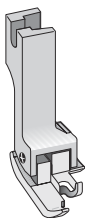

SC45

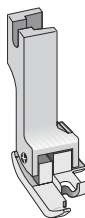

SC55

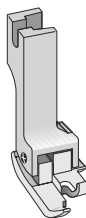

SC65



SC75



SC85

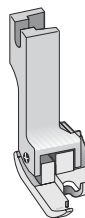

SC95

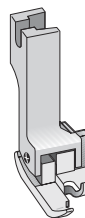

SC105

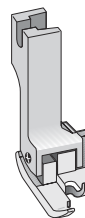

Sizes Details

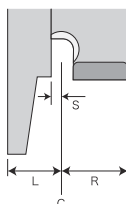

C = Hole in center
 L = Left width from needle
 R = Right width from needle
 S = Stitch margin

Part No.	L	R	S
SC40	5.55 mm	2.5 mm	0.8 mm
SC45	5.55 mm	3.0 mm	0.8 mm
SC55	5.55 mm	4.0 mm	0.8 mm
SC65	5.75 mm	5.0 mm	1.0 mm
SC75	5.75 mm	6.0 mm	1.0 mm
SC85	5.95 mm	7.0 mm	1.2 mm
SC95	5.95 mm	8.0 mm	1.2 mm
SC105	5.95 mm	9.0 mm	1.2 mm

Parts Details

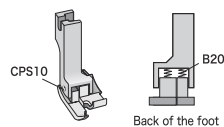

Part No.	Description	Foot No.
B20	Spring for feet	All feet
CPS10	Screw for feet	All feet

NOTE

- These feet keep much stabler stitch margin because left guide shoe holds edge of binding or hemming.
- SC series is specially best for A5S binders.
- Referred on page 51 for applicable each binder.

BINDING FEET

SUISEI
OSAKA JAPAN

Compensating Binding Feet for Wide Stitch Margin

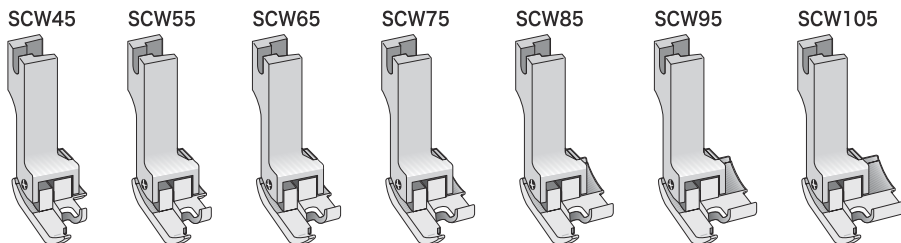

Sizes Details

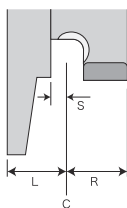

C = Hole in center
L = Left width from needle
R = Right width from needle
S = Stitch margin

Part No.	L	R	S
SCW45	6.25 mm	2.3 mm	1.5 mm
SCW55	6.25 mm	3.3 mm	1.5 mm
SCW65	6.75 mm	4.0 mm	2.0 mm
SCW75	6.75 mm	5.0 mm	2.0 mm
SCW85	6.75 mm	6.0 mm	2.0 mm
SCW95	6.75 mm	7.0 mm	2.0 mm
SCW105	6.75 mm	8.0 mm	2.0 mm

Parts Details

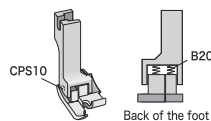

Part No.	Description	Foot No.
B20	Spring for feet	All feet
CPS10	Screw for feet	All feet

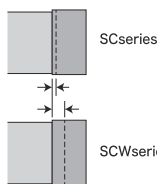

SCW series make wide-margin stitching with binders on left illustration.

NOTE

- These feet keep much stabler stitch margin because left guide shoe holds edge of binding or hemming.
- SC series is specially best for A5S binders.
- Referred on page 51 for applicable each binder.

BINDING FEET

SUISEI
 OSAKA JAPAN

Feet for A50 Hemmers

SHA25Z

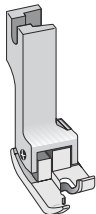

SHA30Z

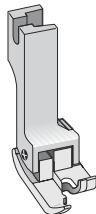

SHA40

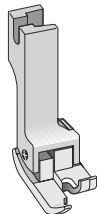

SHA50

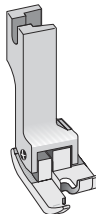

SHA60

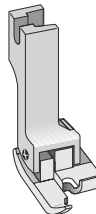

SHA70

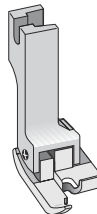

SHA80

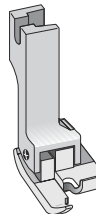

SHA100

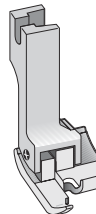

Sizes Details

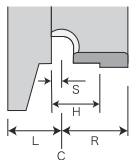

C = Hole in center
 L = Left width from needle
 R = Right width from needle
 S = Stitch margin
 H = Hem size

Part No.	L	R	S	H	Hemmer No.
SHA25Z	5.25 mm	5.25 mm	0.5 mm	2.5 mm	A50-2,5
SHA30Z	5.25 mm	5.25 mm	0.5 mm	3.0 mm	A50-3
SHA40	5.55 mm	4.95 mm	0.8 mm	4.0 mm	A50-4
SHA50	5.55 mm	5.95 mm	0.8 mm	5.0 mm	A50-5
SHA60	5.75 mm	7.25 mm	1.0 mm	6.0 mm	A50-6
SHA70	5.75 mm	7.25 mm	1.0 mm	7.0 mm	A50-7
SHA80	5.95 mm	7.80 mm	1.2 mm	8.0 mm	A50-8
SHA100	5.95 mm	8.00 mm	1.2 mm	—	A50-10

Parts Details

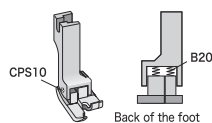

Part No.	Description	Foot No.
B20	Spring for feet	All feet
CPS10	Screw for feet	All feet

NOTE

These feet keep much stabler stitch margin because left guide shoe holds edge of binding or hemming.

BINDING FEET

SUISEI
OSAKA JAPAN

Feet for Folders & Hemmers

SP3613

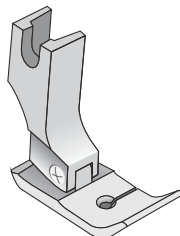

SP3619

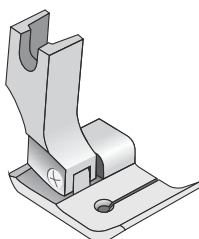

SP3625

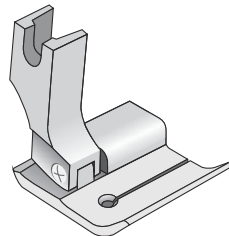

Sizes Details

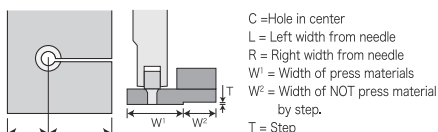

Part No.	L	R	W ¹	W ²	T
SP3613	6.0 mm	7.0 mm	12.0 mm	0.0 mm	0.0 mm
SP3619	6.0 mm	13.0 mm	12.0 mm	7.0 mm	0.5 mm
SP3625	6.0 mm	19.0 mm	12.0 mm	13.0 mm	0.5 mm

W² of SP3613 is 0.0mm = Flat bottom.

Parts Details

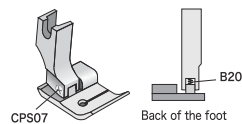

Part No.	Description	Foot No.
B20	Spring for foot	All feet
CPS07	Screw for foot	All feet

Difference Binding feet with Folder & Hemmers feet

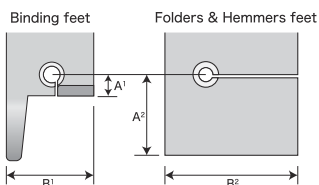

Feet for Folders & Hemmers are appropriate for straight sewing to press materials by wide bottom.

For large size of A5S, A5BS, A11S and A110S folders & hemmers.

NOTE

Referred below for applicable each folders and hemmers.
A5S series (Page 56) · A5BS series (Page 57) · A11S series (Page 65) · A110S series (Page 66)

BINDING FEET

SUISEI
OSAKA JAPAN

Guide Feet for Folders & Hemmers

SP3811

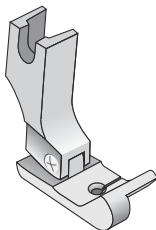

SP3819

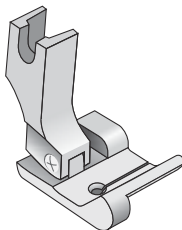

SP3825

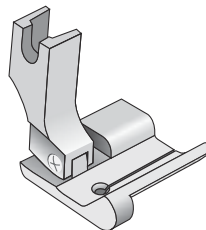

Sizes Details

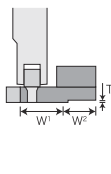
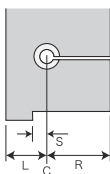

C = Hole in center
L = Left width from needle
R = Right width from needle
W¹ = Width of press materials
W² = Width of NOT press material by step.
T = Step
S = Stitch margin

Part No.	L	R	W ¹	W ²	T	S
SP3811	6.0 mm	6.0 mm	7.7 mm	0.0 mm	0.0 mm	1.7 mm
SP3819	6.0 mm	13.0 mm	7.7 mm	7.0 mm	0.5 mm	1.7 mm
SP3825	6.0 mm	19.0 mm	7.7 mm	13.0 mm	0.5 mm	1.7 mm

W² of SP3811 is 0.0mm = Flat bottom.

Parts Details

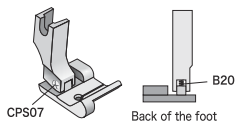

CPS07

Back of the foot

Part No.	Description	Foot No.
B20	Spring for feet	All feet
CPS07	Screw for feet	All feet

Difference Binding feet with Folder & Hemmers feet

Binding feet

Folders & Hemmers feet

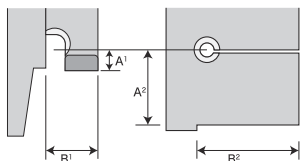

Feet for Folders & Hemmers are appropriate for straight sewing to press materials by wide bottom.

For large size of A5S, A5BS, A11S and A110S folders & hemmers.

NOTE

Referred below for applicable each folders and hemmers.

A5S series (Page 56) · A5BS series (Page 57) · A11S series (Page 65) · A110S series (Page 66)

Standard Easy Feet

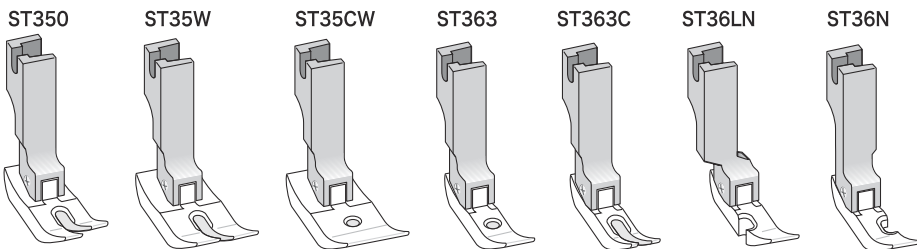

Sizes Details

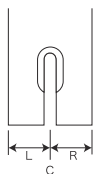

C = Hole in center
L = Left width from needle
R = Right width from needle

Part No.	L	R
ST350	5.5 mm	5.5 mm
ST35W	6.5 mm	6.5 mm
ST35CW	6.5 mm	6.5 mm
ST363	3.0 mm	3.0 mm
ST363C	3.0 mm	3.0 mm
ST36LN	0.5 mm	5.5 mm
ST36N	5.5 mm	0.5 mm

Parts Details

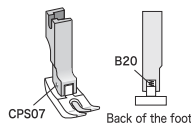

Part No.	Description	Foot No.
B20	Spring for feet	All feet
CPS07	Screw for feet	All feet

Easy Feet type List

ST350
Regular Type



ST35W
Double Toe Even Type



ST35CW
Hole In Center Type



ST363
For Zipper
Hole In Center Type



ST363C
For Zipper



ST36LN
For Left Cording



ST36N
For Right Cording



NOTE

- Easy feet is made by fluororesin.
- Enable to buy only bottom parts.
(Include with B20)

Piping Easy Feet

STP20L

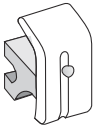
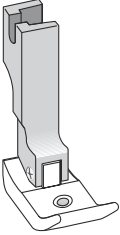

STP30L

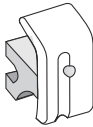
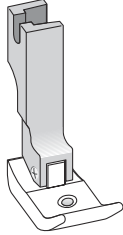

STP35L

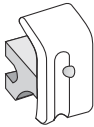
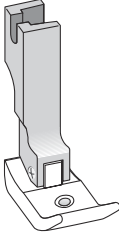

STP20R

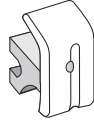
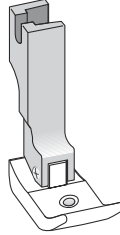

STP30R

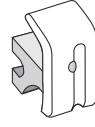
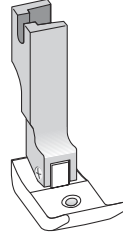

STP35R

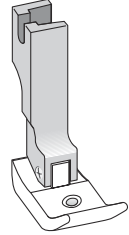

Sizes Details

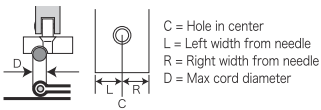

Part No.	L	R	D
STP20L	6,5 mm	6,5 mm	2,0 mm
STP30L	6,5 mm	6,5 mm	3,0 mm
STP35L	6,5 mm	6,5 mm	3,5 mm
STP20R	6,5 mm	6,5 mm	2,0 mm
STP30R	6,5 mm	6,5 mm	3,0 mm
STP35R	6,5 mm	6,5 mm	3,5 mm

Parts Details

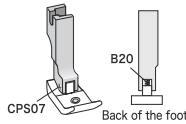

Part No.	Description	Foot No.
B20	Spring for feet	All feet
CPS07	Screw for feet	All feet

Easy Feet for Needle Feed Machines

ST350NF

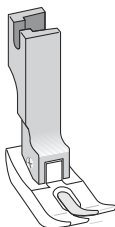

ST35WNF

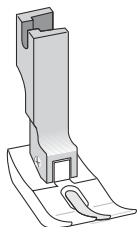

ST35CWNF

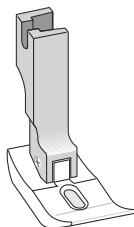

ST363NF

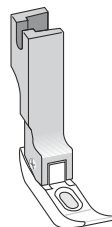

ST363CNF

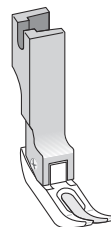

For Needle feed machine. Referred on page 33 for one needle lock stitch machine.

Sizes Details

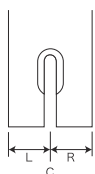

C = Hole in center
L = Left width from needle
R = Right width from needle

Part No.	L	R
ST350NF	5,5 mm	5,5 mm
ST35WNF	6,5 mm	6,5 mm
ST35CWNF	6,5 mm	6,5 mm
ST363NF	3,0 mm	3,0 mm
ST363CNF	3,0 mm	3,0 mm

Parts Details

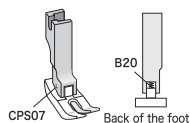

Part No.	Description	Foot No.
B20	Spring for feet	All feet
CPS07	Screw for feet	All feet

Easy Feet for Needle Feed Machine type List

ST350NF
Regular Type

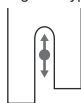

ST35WNF
Double Toe Even Type

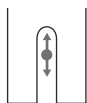

ST35CWNF
Hole In Center Type

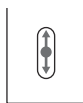

ST363NF
For Zipper
Hole In Center Type



ST363CNF
For Zipper



NOTE

- Easy feet is made by fluororesin.
- Enable to buy only bottom parts. (Include with B20)



Right Compensating Feet for Knit & Thin Materials

SR10KZ

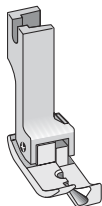

SR15KZ

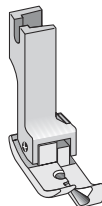

SR20KZ

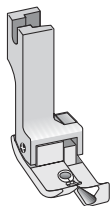

SR25KZ

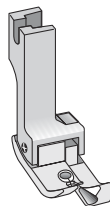

SR30KZ

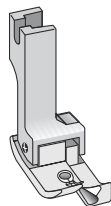

SR40KZ

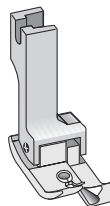

SR50KZ

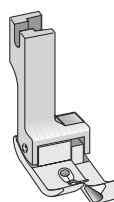

SR60KZ

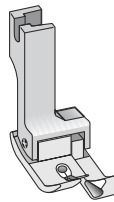

SR65KZ

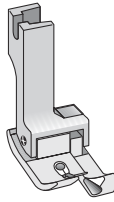

SR10NKZ

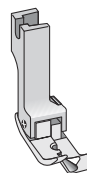

SR15NKZ

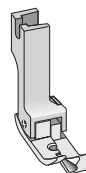

Narrow type

Sizes Details

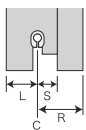
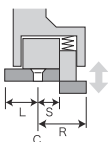

C = Hole in center
L = Left width from needle
S = Stitch margin
R = Right width from needle

Part No.	L	S	R
SR10KZ	5.75 mm	1.0 mm	5.75 mm
SR15KZ	5.25 mm	1.5 mm	6.25 mm
SR20KZ	6.25 mm	2.0 mm	6.75 mm
SR25KZ	6.00 mm	2.5 mm	7.25 mm
SR30KZ	6.00 mm	3.0 mm	7.75 mm
SR40KZ	6.00 mm	4.0 mm	8.75 mm
SR50KZ	6.25 mm	5.0 mm	9.75 mm
SR60KZ	6.00 mm	6.0 mm	10.75 mm
SR65KZ	6.00 mm	6.5 mm	11.25 mm
SR10NKZ	4.75 mm	1.0 mm	5.75 mm
SR15NKZ	4.25 mm	1.5 mm	6.25 mm

Parts Details

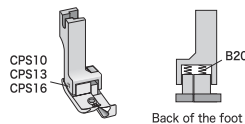

Part No.	Description	Foot No.
B20	Spring for feet	All feet
CPS10	Screw for feet	SR10KZ, SR15KZ SR10NKZ, SR15NKZ
CPS13	Screw for feet	SR20KZ, SR25KZ SR30KZ, SR40KZ
CPS16	Screw for feet	SR50KZ, SR60KZ SR65KZ

Needle Hole Type

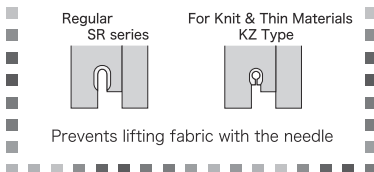



FEET FOR KNIT & THIN MATERIALS

SUISEI
OSAKA JAPAN

Standard Foot for Knit & Thin Materials

SP351KZ

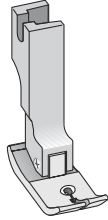

Sizes Details



C = Hole in center
L = Left width from needle
R = Right width from needle

Part No.	L	R
SP351KZ	6.0 mm	5.0 mm

Parts Details

Part No.	Description
B20	Spring for feet
CPS07	Screw for feet

NOTE

SP351KZ

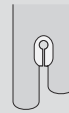

Prevents lifting fabric with the needle



Hinged Cording Feet (Hinged Concealed Seam Feet)

SP36N

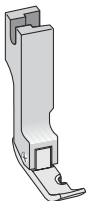

SP36

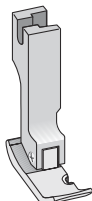

SP36LN

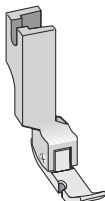

SP36L

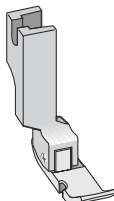

Parts Details

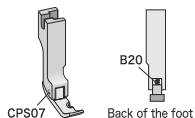

Part No.	Description	Foot No.
B20	Spring for feet	All feet
CPS07	Screw for feet	All feet

Sizes Details

SP36N
SP36



SP36LN
SP36L



C = Hole in center
L = Left width from needle
R = Right width from needle

Part No.	L	Part No.	R
SP36N	5,0 mm	SP36LN	5,0 mm
SP36	8,0 mm	SP36L	8,0 mm

Solid Cording Feet (Solid Concealed Seam Feet)

P311N

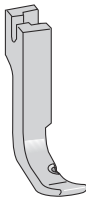

P31

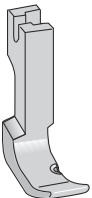

P301N

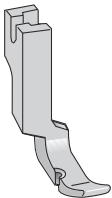

P301

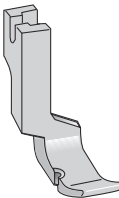

Sizes Details

P311N
P31



P301N
P301

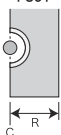

C = Hole in center
L = Left width from needle
R = Right width from needle

Part No.	L	Part No.	R
P311N	5,0 mm	P301N	5,0 mm
P31	8,0 mm	P311	8,0 mm

HEMMER FEET

SUISEI
OSAKA JAPAN

Ball Hemmer Feet (for Extra Thin & Thin Materials)

H6010- $\frac{1}{16}$

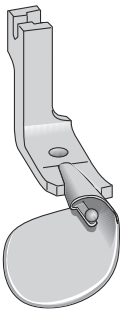

H6010- $\frac{1}{8}$

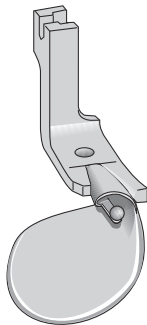

H6010- $\frac{3}{16}$

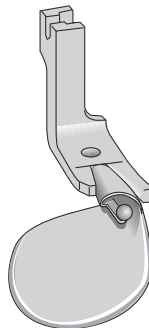

H6010- $\frac{1}{4}$

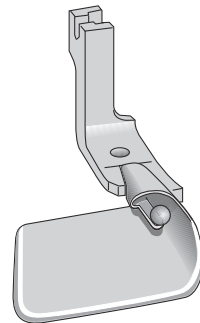

Sizes Details

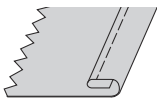

C = Needle
W = Hem size

Part No.	W	Materials
H6010- $\frac{1}{16}$	1.6 mm	Extra Thin
H6010- $\frac{1}{8}$	3.2 mm	Thin
H6010- $\frac{3}{16}$	4.8 mm	Thin
H6010- $\frac{1}{4}$	6.4 mm	Thin

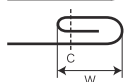

NOTE

- For straight stitch and gentle curving.
- This hemmers is for extra thin and thin materials.

Hem size

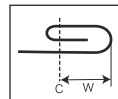
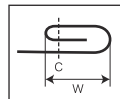

Top Stitch Feller Feet

H5017- $\frac{3}{16}$

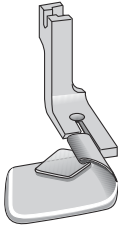

H5019- $\frac{3}{16}$

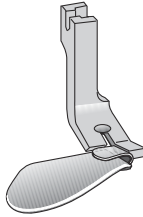

H5019- $\frac{1}{4}$

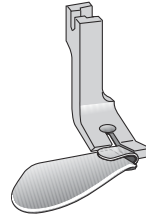

H5019R- $\frac{3}{16}$

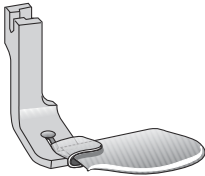

H5019R- $\frac{1}{4}$

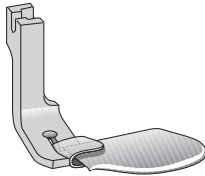

H5020- $\frac{3}{16}$

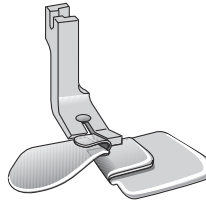

H5020- $\frac{1}{4}$

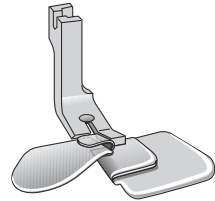

Sizes Details

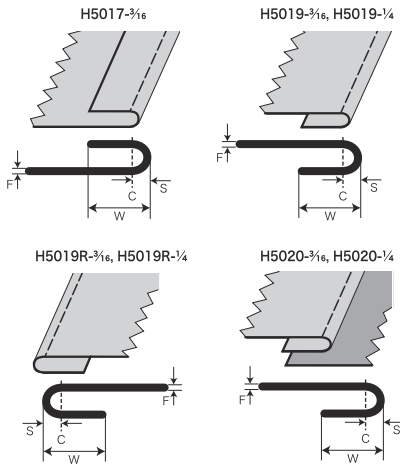

C = Needle
W = Feller size
S = Stitch margin
F = Material thickness

Part No.	W	S	F
H5017- $\frac{3}{16}$	4.8 mm	1.0 mm	1.0 mm
H5019- $\frac{3}{16}$	4.8 mm	1.0 mm	0.5 mm
H5019- $\frac{1}{4}$	6.4 mm	1.0 mm	0.5 mm
H5019R- $\frac{3}{16}$	4.8 mm	1.0 mm	0.5 mm
H5019R- $\frac{1}{4}$	6.4 mm	1.0 mm	0.5 mm
H5020- $\frac{3}{16}$	4.8 mm	1.0 mm	1.0 mm
H5020- $\frac{1}{4}$	6.4 mm	1.0 mm	1.0 mm

FEET FOR NEEDLE FEED MACHINES

SUISEI
OSAKA JAPAN

Spring Guide Feet for Needle Feed Machines

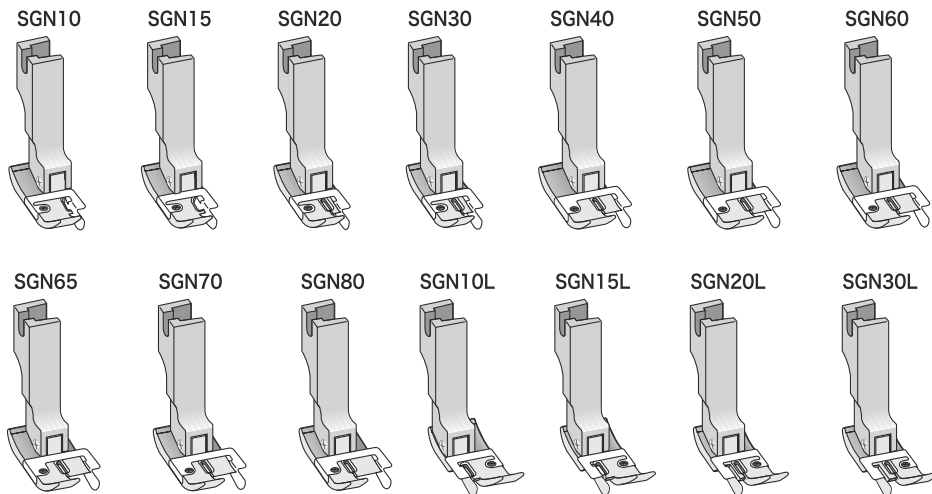

For Needle feed machine. Referred on page 1 for one needle lock stitch machine.

Sizes Details

Right Guide

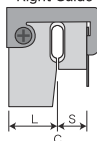

Left Guide

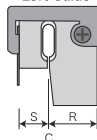

C = Hole in center
S = Stitch margin
L = Left width from needle
R = Right width from needle

Part No.	L (R)	S
SGN10	8.2 mm	1.0 mm
SGN15	7.7 mm	1.5 mm
SGN20	7.2 mm	2.0 mm
SGN30	6.2 mm	3.0 mm
SGN40	10.0 mm	4.0 mm
SGN50	9.0 mm	5.0 mm
SGN60	8.0 mm	6.0 mm
SGN65	7.5 mm	6.5 mm
SGN70	7.0 mm	7.0 mm
SGN80	6.0 mm	8.0 mm
SGN10L	8.2 mm	1.0 mm
SGN15L	7.7 mm	1.5 mm
SGN20L	7.2 mm	2.0 mm
SGN30L	6.2 mm	3.0 mm

Parts Details

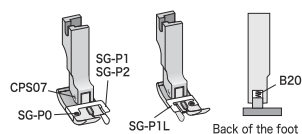

Part No.	Description	Foot No.
B20	Spring for feet	All feet
CPS07	Screw for feet	All feet
SG-P0	Screw (M1.6 × 0.35)	All feet
SG-P1	Spring guide	SG10, SG15, SG20, SG30, SG110, SG150, SG200
SG-P2	Spring guide	SG40, SG50, SG60, SG65, SG70, SG80
SG-P1L	Spring guide	SG10L, SG15L, SG20L, SG30L

NOTE

For straight and curving edges. NO guide part at the rear of the needle hole.



CAUTION

The lower material can be hurt by the spring guide when it is weak and thin.



Compensating Feet for Needle Feed Machines

SR10NF

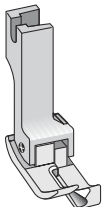

SR15NF

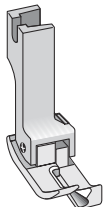

SR20NF

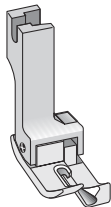

SR25NF

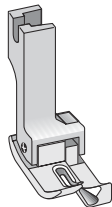

SR30NF

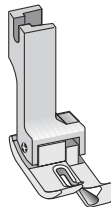

SL10NF

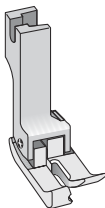

SL15NF

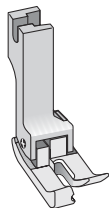

SL20NF

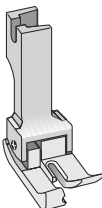

SL25NF

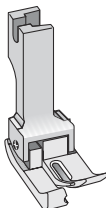

SL30NF

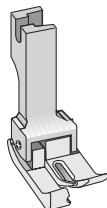

For Needle feed machine, Referred on page 4 and 7 for one needle lock stitch machine.

Sizes Details

SR (Right Guide)

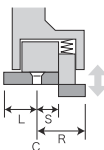

C = Hole in center
L = Left width from needle
S = Stitch margin
R = Right width from needle

Part No.	L	S	R
SR10NF	5,75 mm	1,0 mm	5,75 mm
SR15NF	5,25 mm	1,5 mm	6,25 mm
SR20NF	6,25 mm	2,0 mm	6,75 mm
SR25NF	6,00 mm	2,5 mm	7,25 mm
SR30NF	6,00 mm	3,0 mm	7,75 mm
SL10NF	5,75 mm	1,0 mm	5,75 mm
SL15NF	6,25 mm	1,5 mm	5,25 mm
SL20NF	6,75 mm	2,0 mm	6,25 mm
SL25NF	7,25 mm	2,5 mm	6,00 mm
SL30NF	7,75 mm	3,0 mm	6,00 mm

SL (Left Guide)

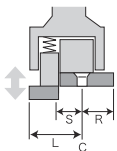

Parts Details

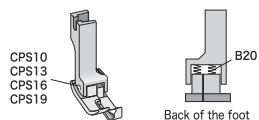

Part No.	Description	Foot No.
B20	Spring for feet	All feet
CPS10	Screw for feet	SR10NF, SR15NF SL10NF, SL15NF
CPS13	Screw for feet	SR20NF, SR25NF SR30NF, SL20NF SL25NF, SL30NF



Quilter Foot with Right & Left Guides for Needle Feed Machines

P723NF

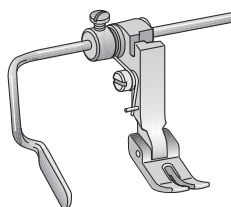
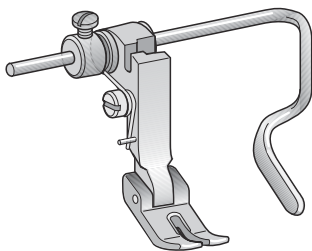

Attach on the Left

For Needle feed machine, Referred on page 3 for one needle lock stitch machine.

Sizes Details

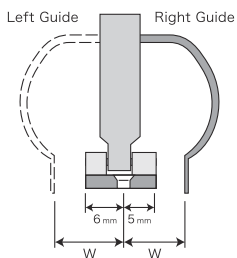

Guides	Stitch margin W
Right Guide	5 ~ 45 mm
Left Guide	6 ~ 45 mm

Parts Details

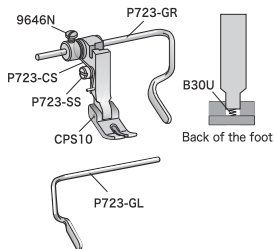

Part No.	Description
B30U	Spring for P723NF
CPS10	Srew for feet
9646N	Screw (9/16"-L6)
P723-SS	Shoulder screw
P723-CS	Spring
P723-GR	Right guide
P723-GL	Left guide



Standard Feet for Needle Feed Machines

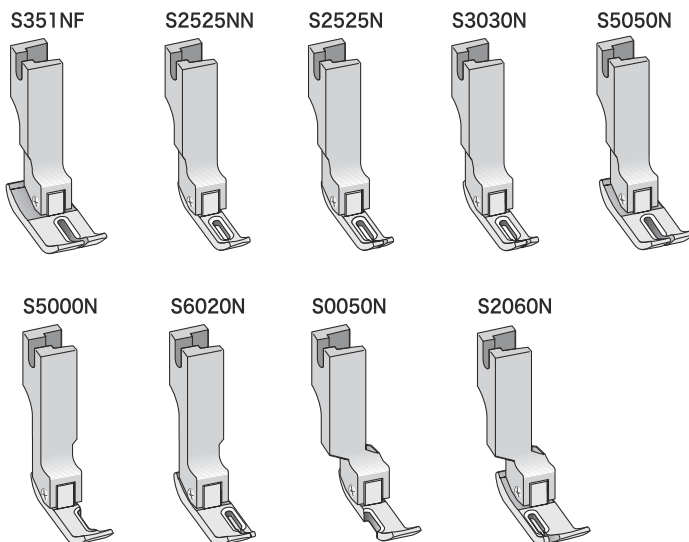

For Needle feed machine. Referred on page 14 to 18 for one needle lock stitch machine.

Sizes Details

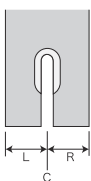

C = Hole in center
L = Left width from needle
R = Right width from needle

Part No.	L	R
S351NF	6.0 mm	5.0 mm
S2525NN	2.5 mm	2.5 mm
S2525N	2.5 mm	2.5 mm
S3030N	3.0 mm	3.0 mm
S5050N	5.0 mm	5.0 mm
S5000N	5.0 mm	0.0 mm
S6020N	6.0 mm	2.0 mm
S0050N	0.0 mm	5.0 mm
S2060N	2.0 mm	6.0 mm

Parts Details

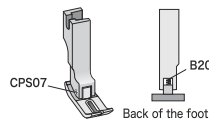

Part No.	Description	Foot No.
B20	Spring for feet	All feet
CPS07	Screw for feet	All feet

Difference S2525NN with S2525N

S2525NN



No Split

S2525N



Split



Hinged Binding feet for Needle Feed Machines

SAN40

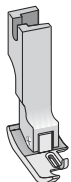

SAN45

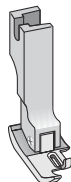

SAN55

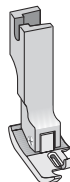

SAN65

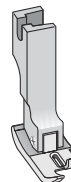

SAN75

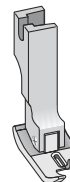

SAN85



SAN95



SAN105

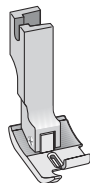

SAN130

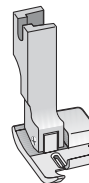

SAN140

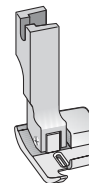

SAN150

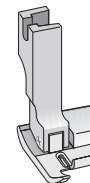

SAN200

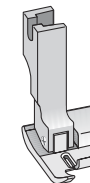

SAN250

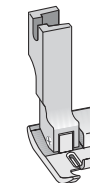

For Needle feed machine, Referred on page 27 for one needle lock stitch machine.

Sizes Details

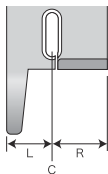

C = Hole in center
L = Left width from needle
R = Right width from needle

Part No.	L	R
SAN40	6.0 mm	2.5 mm
SAN45	6.0 mm	3.0 mm
SAN55	6.0 mm	4.0 mm
SAN65	6.0 mm	5.0 mm
SAN75	6.0 mm	6.0 mm
SAN85	6.0 mm	7.0 mm
SAN95	6.0 mm	8.0 mm
SAN105	6.0 mm	9.0 mm
SAN130	6.0 mm	11.0 mm
SAN140	6.0 mm	12.0 mm
SAN150	6.0 mm	13.0 mm
SAN200	6.0 mm	18.0 mm
SAN250	6.0 mm	22.0 mm

Parts Details

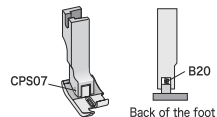

Part No.	Description	Foot No.
B20	Spring for feet	All feet
CPS07	Screw for feet	All feet

NOTE

Referred on page 51 for applicable each binder.



Easy Feet for Needle Feed Machines

ST350NF

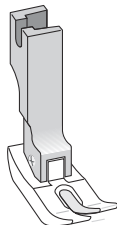

ST35WNF

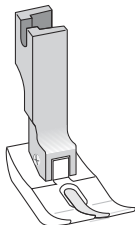

ST35CWNF

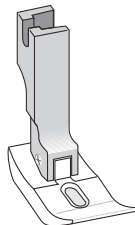

ST363NF

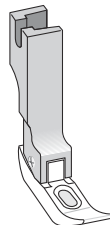

ST363CNF

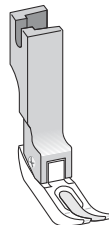

For Needle feed machine. Referred on page 33 for one needle lock stitch machine.

Sizes Details



C = Hole in center
L = Left width from needle
R = Right width from needle

Part No.	L	R
ST350NF	5.5 mm	5.5 mm
ST35WNF	6.5 mm	6.5 mm
ST35CWNF	6.5 mm	6.5 mm
ST363NF	3.0 mm	3.0 mm
ST363CNF	3.0 mm	3.0 mm

Parts Details

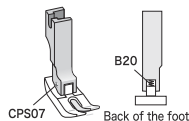

Part No.	Description	Foot No.
B20	Spring for feet	All feet
CPS07	Screw for feet	All feet

Easy Feet for Needle Feed Machine type List

ST350NF
Regular Type

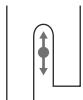

ST35WNF
Double Toe Even Type

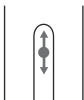

ST35CWNF
Hole In Center Type



ST363NF
For Zipper
Hole In Center Type



ST363CNF
For Zipper



NOTE

- Easy feet is made by fluororesin.
- Enable to buy only bottom parts.
(Include with B20)



Hinged Feet for Zig-Zag Machines

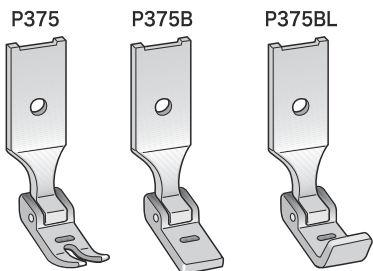

For Zig-Zag machine.

NOT enable to use One needle lock stitch machine.

Sizes Details



C = Hole in center
L = Left width from needle
R = Right width from needle

Part No.	L	R
P375	5.0 mm	5.0 mm
P375B	5.0 mm	5.0 mm
P375BL	5.0 mm	5.0 mm

NOTE

P375B and P375BL is not hardened, and can be easily cut away as you like.



Two Needle Compensating Feet for Thin Materials

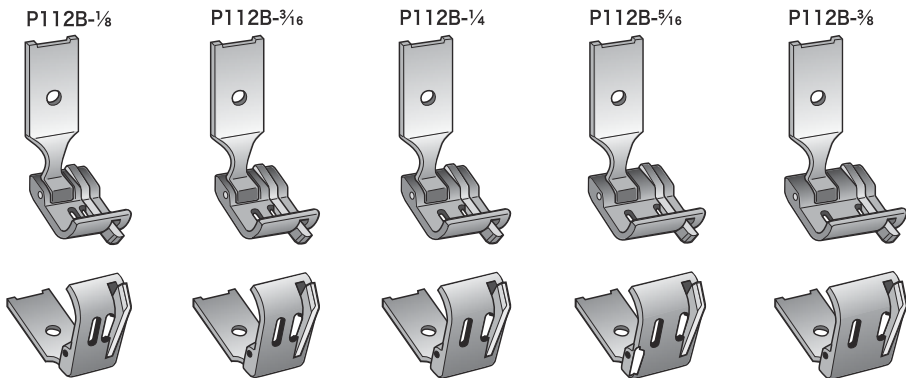

For two needle machine. NOT enable to use One needle lock stitch machine.

Sizes Details

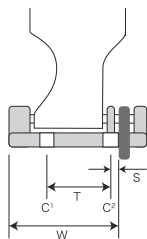

C¹ = Left needle
C² = Right needle
T = Width between C¹ and C²
S = Stitch margin
W = Left width from guide

Part No.	T	S	W
P112B- $\frac{1}{8}$	3.2 mm	1.0 mm	10.0 mm
P112B- $\frac{3}{16}$	4.8 mm	1.0 mm	11.0 mm
P112B- $\frac{1}{4}$	6.4 mm	1.0 mm	12.5 mm
P112B- $\frac{5}{16}$	8.0 mm	1.0 mm	14.5 mm
P112B- $\frac{3}{8}$	9.5 mm	1.0 mm	16.0 mm

Parts Details

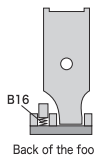

Part No.	Description	Foot No.
B16	Spring for P112	All feet

NOTE

For brassiere as thin materials.

FEET FOR SPECIAL MACHINES

SUISEI
OSAKA JAPAN

Two Needle Compensating Feet for Medium Materials

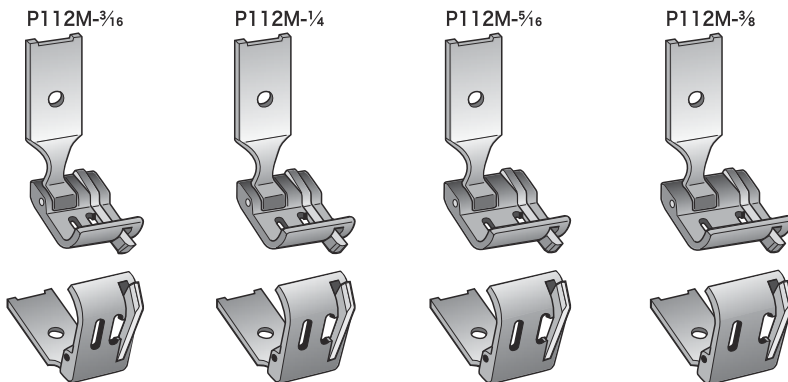

For two needle machine. NOT enable to use One needle lock stitch machine.

Sizes Details

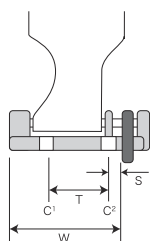

C¹ = Left needle
C² = Right needle
T = Width between C¹ and C²
S = Stitch margin
W = Left width from guide

Part No.	T	S	W
P112M- $\frac{3}{16}$	4,8 mm	1,5 mm	12,0 mm
P112M- $\frac{1}{4}$	6,4 mm	1,5 mm	13,0 mm
P112M- $\frac{5}{16}$	8,0 mm	1,5 mm	15,0 mm
P112M- $\frac{3}{8}$	9,5 mm	1,5 mm	16,5 mm

Parts Details

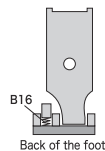

Part No.	Description	Foot No.
B16	Spring for P112	All feet

NOTE

For shirts as medium materials.



Two Needle Compensating Feet for Heavy Materials

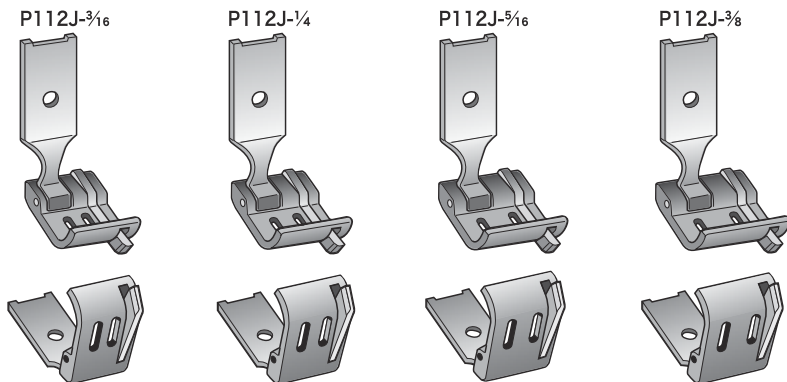

For two needle machine. NOT enable to use One needle lock stitch machine.

Sizes Details

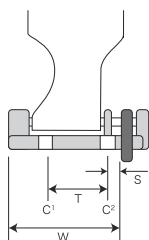

C¹ = Left needle
C² = Right needle
T = Width between C¹ and C²
S = Stitch margin
W = Left width from guide

Part No.	T	S	W
P112J- $\frac{3}{16}$	4.8 mm	2.0 mm	12.0 mm
P112J- $\frac{1}{4}$	6.4 mm	2.0 mm	13.5 mm
P112J- $\frac{5}{16}$	8.0 mm	2.0 mm	15.5 mm
P112J- $\frac{3}{8}$	9.5 mm	2.0 mm	17.0 mm

Parts Details

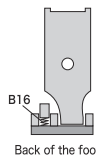

Back of the foot

Part No.	Description	Foot No.
B16	Spring for P112	All feet

NOTE

For jeans as heavy materials.

SIZE TABLE

Hinged Binding Feet SA series

	A10S-	A10H-	A1S-	A2S-	A4S-	A9S-	A5S-	A5BS-	A11S-	A110S-
SA40	16		16,18,20	20	10					
SA45	18, 20	24	22	22						
SA55	22, 24	26, 28	24, 26	24, 26	13	25	5	5	6	
SA65	26, 28	30, 32	28, 30	28, 30	16	28, 32				
SA75	30, 32		32	32			8	8	8	8
SA85	36	36	36		20, 22	38	10	10		
SA95		40	40						10	10
SA105	40	45			25		12	12		
SA130	45	50					15	15	13	
SA140	50									
SA150							18, 20	18, 20	15, 18	15
SA200							24, 30	24	20	20
SA250							40		25 ~	25

Hinged Binding Feet for Needle Feed Machine SAN series

	A1S-	A2S-	A4S-	A9S-	A5S-	A5BS-	A11S-	A110S-
SAN40	16,18,20	20	10					
SAN45	22	22						
SAN55	24, 26	24, 26	13	25	5	5	6	
SAN65	28, 30	28, 30	16	28, 32				
SAN75	32	32			8	8	8	8
SAN85	36		20, 22	38	10	10		
SAN95	40						10	10
SAN105			25		12	12		
SAN130					15	15	13	
SAN140								
SAN150					18, 20	18, 20	15, 18	15
SAN200					24, 30	24	20	20
SAN250					40		25 ~	25

Compensating Binding Feet SC series

	A10C-	A10HC-	A1S-	A2S-	A4S-	A9S-	A5S-	A5BS-	A11S-	A110S-
SC40	16, 18		16,18,20	20	10					
SC45	20, 22	24	22	22						
SC55	24, 26	26, 28	24, 26	24, 26	13	25	5	5	6	
SC65	28	30, 32	28, 30	28, 30	16	28, 32				
SC75	30, 32		32	32			8	8	8	8
SC85	36	36	36		20, 22	38	10	10		
SC95		40	40						10	10
SC105	40,45,50	45, 50			25		12 ~	12 ~	13 ~	15,20,25

Compensating Binding Feet for Wide Stitch Margin SCW series

	A10CW-	A10HCW-	A1S-	A2S-	A4S-	A9S-	A5S-	A5BS-	A11S-	A110S-
SCW45	18, 20	24	18, 20	20	10					
SCW55	22, 24	26, 28	22	22						
SCW65	26, 28	30, 32	24, 26	24, 26	13	25	5	5	6	
SCW75	30, 32		28, 30	28, 30	16	28, 32				
SCW85	36	36	32	32			8	8	8	8
SCW95		40	36		20, 22	38	10	10	10	10
SCW105	40,45,50	45, 50	40		25		12 ~	12 ~	13 ~	15,20,25

BINDERS, FOLDERS, HEMMERS, and FELLERS

SUISEI®
OSAKA JAPAN

TAPE GUIDES

SUISEI
OSAKA JAPAN

Adjustable Tape Feet

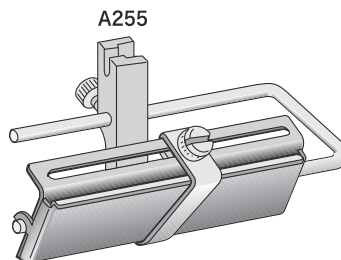
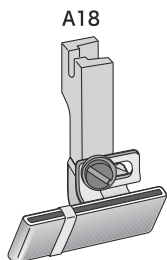

Sizes Details

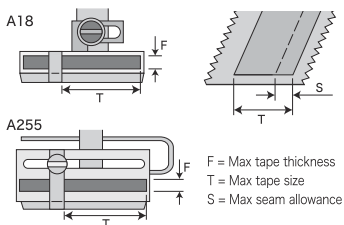

Part No.	F	T	S
A18	1.0 mm	28 mm	12 mm
A255	1.5 mm	53 mm	52 mm

A18 Parts Details

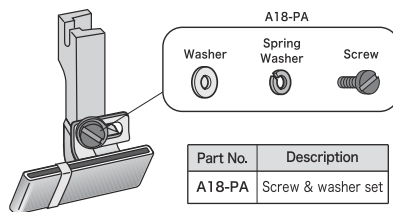

A255 Parts Details

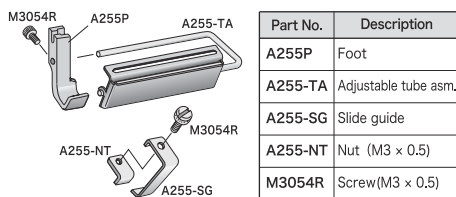

NOTE

This foot can be used at right or left side by adjustable guide position.

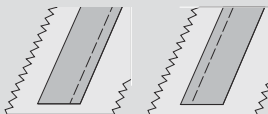

Bias Cord Piping Foot

A20-18

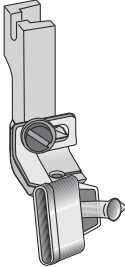

P37

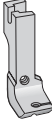

P37M

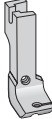

P37W

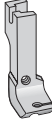

Regular set is fixed P37M.
If not appropriate to the finish, please change to P37 or P37W feet are also available at extra cost. (Referred on Page 21)

Referred below table parts number of each tape size.

Sizes Details

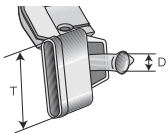

T = Tape size
D = Max cord diameter

Part No.	T	D
A20-18	18 mm	3.0 mm
A20-20	20 mm	3.0 mm
A20-22	22 mm	3.0 mm
A20-24	24 mm	3.5 mm
A20-26	26 mm	3.5 mm
A20-28	28 mm	3.5 mm

Parts Details

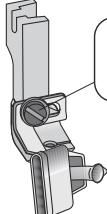

A18-PA

Washer



Spring Washer



Screw



Part No.	Description
A18-PA	Screw & washer set

With cord

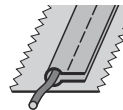

Without cord

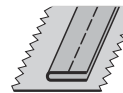

Bias Loop Piping Foot

A21-3

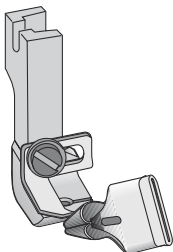

Referred right table parts number of each tape size.

Sizes Details

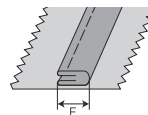

F = Finished size
T = Bias tape size

Part No.	T	F
A21-3	12 mm	3.0 mm
A21-4	16 mm	4.0 mm
A21-5	20 mm	5.0 mm
A21-6.5	25 mm	6.5 mm

Parts Details

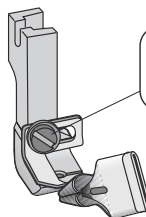

A18-PA

Washer

Spring Washer

Screw



Part No.	Description
A18-PA	Screw & washer set

STRAIGHT FOLDERS

SUISEI
OSAKA JAPAN

Belt and Loop Folder

A5S-5

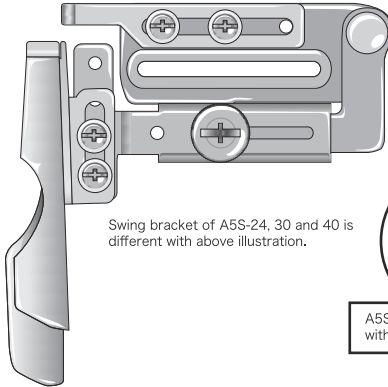

Swing bracket of A5S-24, 30 and 40 is different with above illustration.



A5S-30 and A5S-40 is include with leveling plate.

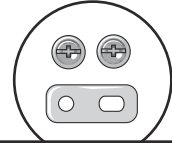

It is include with washer and screw.

Referred below table parts number of each sizes details.

Sizes Details

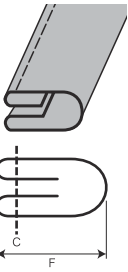

C = Needle
F = Finished Size

Part No.	T	F
A5S-5	18 mm	5 mm
A5S-8	26 mm	8 mm
A5S-10	30 mm	10 mm
A5S-12	36 mm	12 mm
A5S-15	45 mm	15 mm
A5S-18	52 mm	18 mm
A5S-20	58 mm	20 mm
A5S-24	70 mm	24 mm
A5S-30	82 mm	30 mm
A5S-40	105 mm	40 mm

T = Tape Size

Parts Details

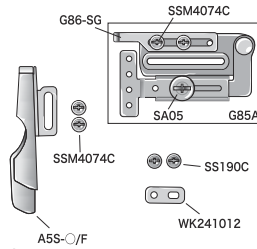

○ is describe each parts number at the left table.

Part No.	Description
A5S-○/F	A5S Folder
G85A	Swing bracket with second guide
G86-SG	Second guide
SA05	Screw (1/4 - L5)
SSM4074C	Screw (M4 × 0.7)
SS190C	Screw (1/4 - L8)
WK241012	Washer

Referred on page 80 for details of swing bracket A5S-24, 30 and 40.

Feet for Folders & Hemmers Applicable parts table

A5S-	5	8	10	12	15	18	20	24	30	40
SP3613		○	○	○						
SP3619					○	○	○			
SP3625								○	○	○
SP3811		○	○	○						
SP3819					○	○	○			
SP3825								○	○	○

NOTE

- A5S binder is specially best for SC series and SP38○○.
- Feet for Folders & Hemmers are appropriate for stable sewing.
- This is not complete full fold.
- Referred on page 77 for how to set folders.

STRAIGHT FOLDERS

SUISEI
OSAKA JAPAN

Straight Folder

A5BS-18

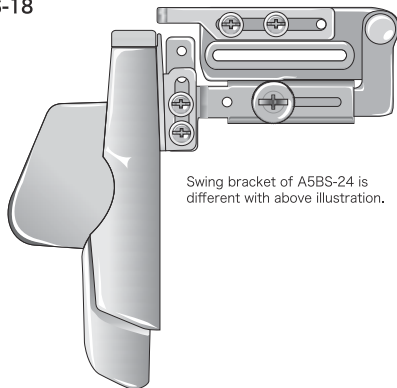

Swing bracket of A5BS-24 is different with above illustration.

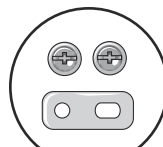

It is include with washer and screw.

Referred below table parts number of each sizes details.

Sizes Details

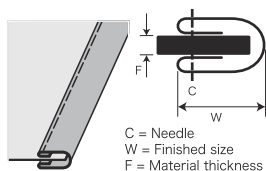

Part No.	T	W	F
A5BS-5	18 mm	5.0 mm	0.5 mm
A5BS-8	26 mm	8.0 mm	0.5 mm
A5BS-10	30 mm	10.0 mm	0.5 mm
A5BS-12	36 mm	12.0 mm	1.0 mm
A5BS-15	45 mm	15.0 mm	1.0 mm
A5BS-18	52 mm	18.0 mm	1.0 mm
A5BS-20	58 mm	20.0 mm	1.0 mm
A5BS-24	70 mm	24.0 mm	1.0 mm

T = Tape Size

Parts Details

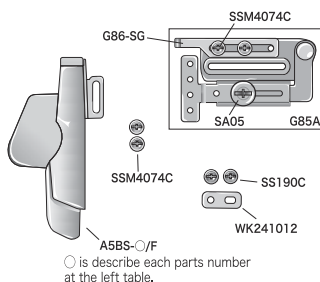

Part No.	Description
A5BS-○/F	A5BS Folder
G85A	Swing bracket with second guide
G86-SG	Second guide
SA05	Screw (3/64 - L5)
SSM4074C	Screw (M4 × 0.7)
SS190C	Screw (3/64 - L8)
WK241012	Washer

Referred on page 80 for details of swing bracket A5BS-24.

NOTE

- A5BS binder is specially best for SC series and SP38○○.
- Feet for Folders & Hemmers are appropriate for stable sewing.
- This is not complete full fold.
- Referred on page 77 for how to set folders.

CAUTION

The contents in above table may be different from fact and depend on material thickness or elasticity of tape. Please use as a measure of size.

Feet for Folders & Hemmers Applicable parts table

A5BS-	5	8	10	12	15	18	20	24
SP3613		○	○	○				
SP3619					○	○	○	
SP3625								○
SP3811		○	○	○				
SP3819					○	○	○	
SP3825								○

RIGHT ANGLE BIAS BINDERS

SUISEI
OSAKA JAPAN

Right Angle Bias Binder (with Presser Foot and Feed Dog)

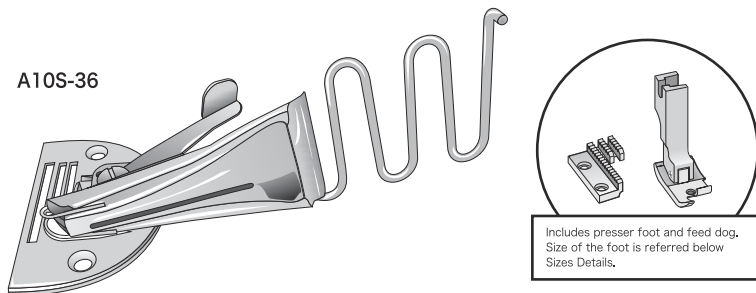

Referred below table parts number of each sizes details.

Sizes Details

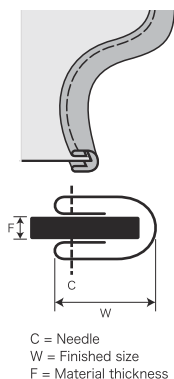

Bias Tape Size	W	F	Part No.(Include Foot)	Part No.(Include Foot)	Part No.(Include Foot)
16 mm	4.0 mm	2.0 mm	A10S-16 (SA40)	A10C-16 (SC40)	—
18 mm	4.5 mm	2.0 mm	A10S-18 (SA45)	A10C-18 (SC40)	A10CW-18 (SCW45)
20 mm	5.0 mm	2.0 mm	A10S-20 (SA45)	A10C-20 (SC45)	A10CW-20 (SCW45)
22 mm	5.5 mm	2.0 mm	A10S-22 (SA55)	A10C-22 (SC45)	A10CW-22 (SCW55)
24 mm	6.0 mm	2.0 mm	A10S-24 (SA55)	A10C-24 (SC55)	A10CW-24 (SCW55)
26 mm	6.5 mm	2.0 mm	A10S-26 (SA65)	A10C-26 (SC55)	A10CW-26 (SCW65)
28 mm	7.0 mm	2.0 mm	A10S-28 (SA65)	A10C-28 (SC65)	A10CW-28 (SCW65)
30 mm	8.0 mm	2.0 mm	A10S-30 (SA75)	A10C-30 (SC75)	A10CW-30 (SCW75)
32 mm	8.5 mm	2.0 mm	A10S-32 (SA75)	A10C-32 (SC75)	A10CW-32 (SCW75)
36 mm	10.0 mm	2.5 mm	A10S-36 (SA85)	A10C-36 (SC85)	A10CW-36 (SCW85)
40 mm	12.0 mm	2.5 mm	A10S-40 (SA105)	A10C-40 (SC105)	A10CW-40 (SCW105)
45 mm	13.0 mm	3.0 mm	A10S-45 (SA130)	A10C45 (SC105)	A10CW-45 (SCW105)
50 mm	16.0 mm	3.0 mm	A10S-50 (SA140)	A10C-50 (SC105)	A10CW-50 (SCW105)

The difference of parts number S, C, and CW is the same binder with different type of feet.

NOTE

For inside curving operation, like neck-line, arm-hole, etc.

Parts Details

Referred on page 60 for Parts Details

CAUTION

The contents in above table may be different from fact and depend on material thickness or elasticity of tape. Please use as a measure of size.

RIGHT ANGLE BIAS BINDERS

SUISEI
OSAKA JAPAN

Right Angle Bias Binder for Heavy Materials (with Presser Foot and Feed Dog)

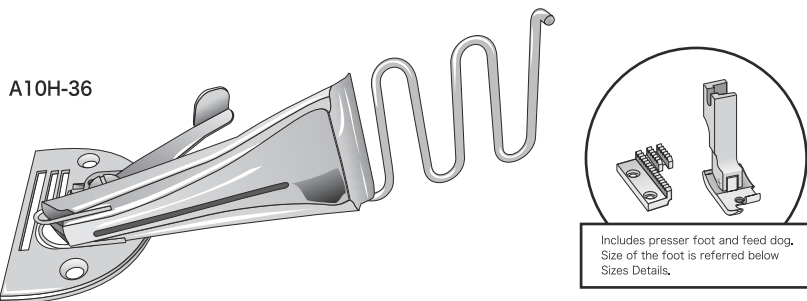

Referred below table parts number of each sizes details.

Sizes Details

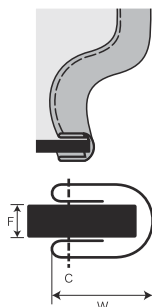

C = Needle
W = Finished size
F = Material thickness

Bias Tape Size	W	F	Part No.(Include Foot)	Part No.(Include Foot)	Part No.(Include Foot)
24 mm	5.5 mm	3.0 mm	A10H-24 (SA45)	A10HC-24 (SC45)	A10HCW-24 (SCW45)
26 mm	6.0 mm	3.0 mm	A10H-26 (SA55)	A10HC-26 (SC55)	A10HCW-26 (SCW55)
28 mm	6.0 mm	3.0 mm	A10H-28 (SA55)	A10HC-28 (SC55)	A10HCW-28 (SCW55)
30 mm	7.0 mm	3.0 mm	A10H-30 (SA65)	A10HC-30 (SC65)	A10HCW-30 (SCW65)
32 mm	7.0 mm	3.5 mm	A10H-32 (SA65)	A10HC-32 (SC65)	A10HCW-32 (SCW65)
36 mm	8.5 mm	3.5 mm	A10H-36 (SA85)	A10HC-36 (SC85)	A10HCW-36 (SCW85)
40 mm	10.5 mm	3.5 mm	A10H-40 (SA95)	A10HC-40 (SC95)	A10HCW-40 (SCW95)
45 mm	11.5 mm	4.0 mm	A10H-45 (SA105)	A10HC-45 (SC105)	A10HCW-45 (SCW105)
50 mm	13.0 mm	4.0 mm	A10H-50 (SA130)	A10HC-50 (SC105)	A10HCW-50 (SCW105)

The difference of parts number H, HC, and HCW is the same binder with different type of feet.

NOTE

For inside curving operation, like neck-line, arm-hole, etc.

Parts Details

Referred on page 60 for Parts Details

CAUTION

The contents in above table may be different from fact and depend on material thickness or elasticity of tape. Please use as a measure of size.

RIGHT ANGLE BIAS BINDERS

SUISEI
OSAKA JAPAN

Right Angle Bias Binder Parts Details

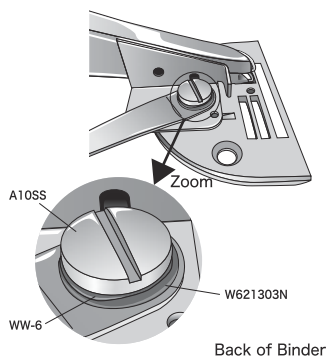
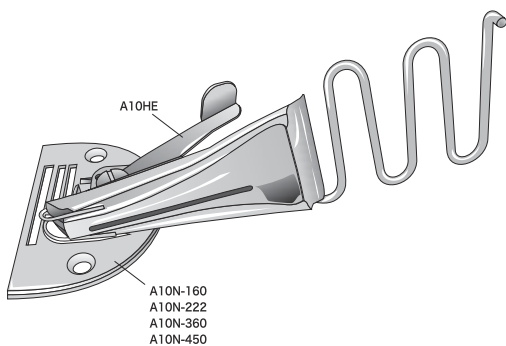

Referred on A10S about A10C and A10CW. Referred on A10H about A10HC and A10HCW.

Part No.	Description	Binder No.
A10HE	Handle for A10S & A10H	All binders
A10N-160	Needle Plate for A10S & A10H	A10S-16, A10S-18, A10S-20
A10N-222	Needle Plate for A10S & A10H	A10S-22, A10S-24, A10S-26 A10S-28, A10S-30 A10H-24, A10H-26, A10H-28 A10H-30
A10N-360	Needle Plate for A10S & A10H	A10S-32, A10S-36, A10S-40 A10H-32, A10H-36, A10H-40
A10N-450	Needle Plate for A10S & A10H	A10S-45, A10S-50 A10H-45, A10H-50

Part No.	Description	Binder No.
A10SS	Screw (1/4")	All binders
WW-6	Wave washer	All binders
W621303N	Plane washer	All binders



DOUBLE FOLD BIAS BINDERS

SUISEI
OSAKA JAPAN

Double Fold Bias Binder

A1S-30

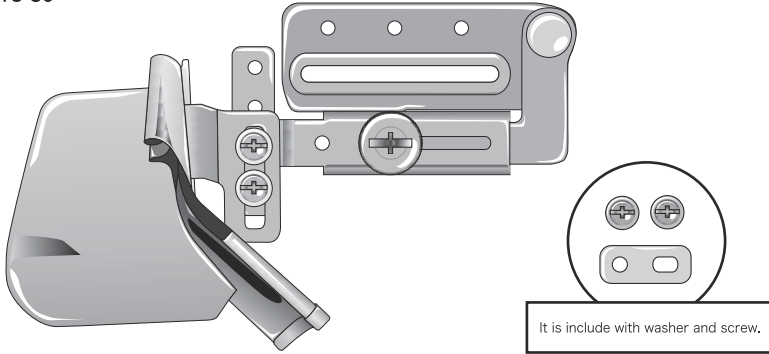

Referred below table parts number of each sizes details.

Sizes Details

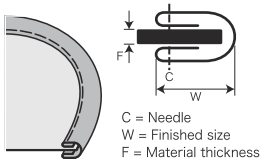

Part No.	T	W	F
A1S-20	20 mm	5.0 mm	1.0 mm
A1S-22	22 mm	5.5 mm	1.0 mm
A1S-24	24 mm	6.0 mm	1.0 mm
A1S-26	26 mm	6.5 mm	1.0 mm
A1S-28	28 mm	7.0 mm	1.0 mm
A1S-30	30 mm	7.5 mm	1.5 mm
A1S-32	32 mm	8.0 mm	1.5 mm
A1S-36	36 mm	9.5 mm	1.5 mm
A1S-40	40 mm	10.5 mm	2.0 mm

T = Bias Tape Size

Parts Details

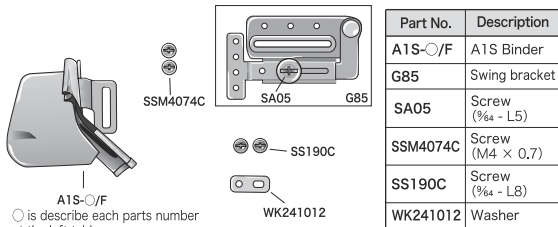

NOTE

- For straight edges and outside curving.
- Referred on page 77 for how to set binders.

CAUTION

The contents in above table may be different from fact and depend on material thickness or elasticity of tape. Please use as a measure of size.

DOUBLE FOLD BIAS BINDERS

SUISEI
OSAKA JAPAN

Double Fold Bias Binder

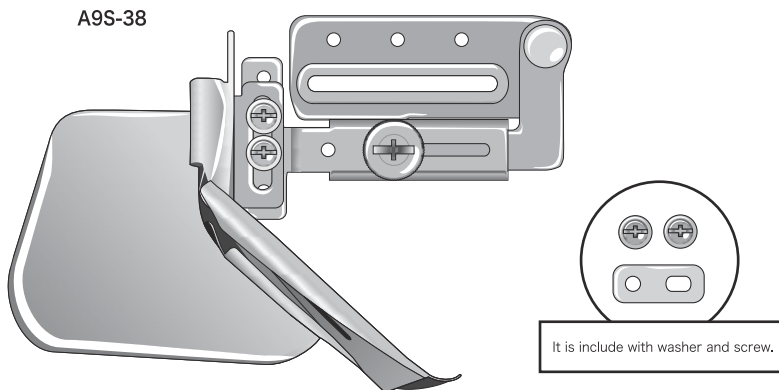

Referred below table parts number of each sizes details.

Sizes Details

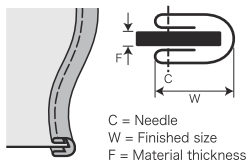

Part No.	T	W	F
A9S-25	25 mm	6.0 mm	1.0 mm
A9S-28	28 mm	7.0 mm	1.5 mm
A9S-32	32 mm	8.0 mm	1.5 mm
A9S-38	38 mm	10.0 mm	2.0 mm

T = Bias Tape Size

Parts Details

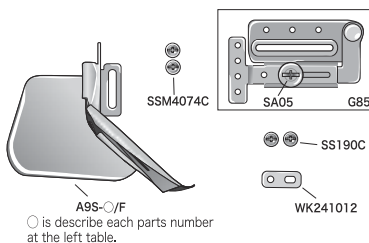

Part No.	Description
A9S-○/F	A9S Binder
G85	Swing bracket
SA05	Screw (3/64 - L5)
SSM4074C	Screw (M4 × 0.7)
SS190C	Screw (3/64 - L8)
WK241012	Washer

NOTE

- A9S makes sewing easy for gentle inside curving and outside curving.
- For a variety of works including thin vinyl tape binding.
- Referred on page 77 for how to set binders.

⚠ CAUTION

The contents in above table may be different from fact and depend on material thickness or elasticity of tape. Please use as a measure of size.

● SINGLE FOLD BIAS BINDERS

SUISEI
OSAKA JAPAN

Single Fold Bias Binder

A2S-22

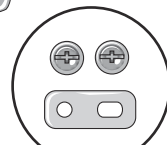
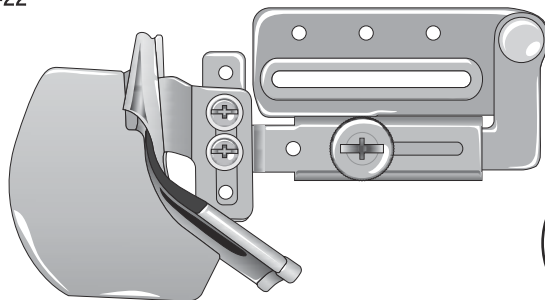

It is include with washer and screw.

Referred below table parts number of each sizes details.

Sizes Details

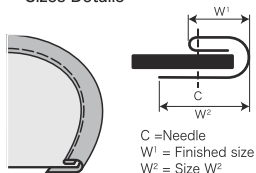

Part No.	T	W ¹	W ²
A2S-20	20 mm	5.0 mm	9.5 mm
A2S-22	22 mm	5.0 mm	10.0 mm
A2S-24	24 mm	6.0 mm	12.0 mm
A2S-26	26 mm	7.0 mm	12.5 mm
A2S-28	28 mm	9.0 mm	12.0 mm
A2S-30	30 mm	10.0 mm	13.0 mm
A2S-32	32 mm	10.5 mm	14.0 mm

T = Bias Tape Size

Parts Details

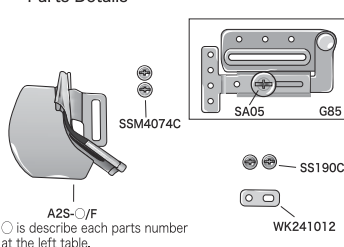

Part No.	Description
A2S-○/F	A2S Binder
G85	Swing bracket
SA05	Screw (3/4 - L5)
SSM4074C	Screw (M4 × 0.7)
SS190C	Screw (3/4 - L8)
WK241012	Washer

NOTE

- For Straight edges and outside curving.
- For thin materials.
- Referred on page 77 for how to set binders.

⚠ CAUTION

The contents in above table may be different from fact and depend on material thickness or elasticity of tape. Please use as a measure of size.

Ball Hemmer Feet (for Extra Thin & Thin Materials)

H6010- $\frac{1}{16}$

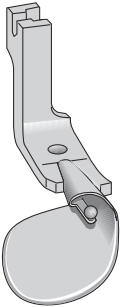

H6010- $\frac{1}{8}$

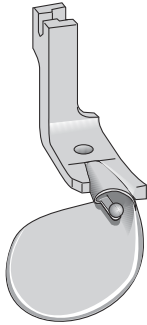

H6010- $\frac{3}{16}$

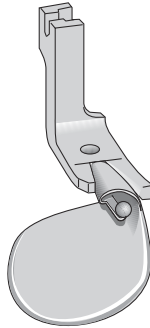

H6010- $\frac{1}{4}$

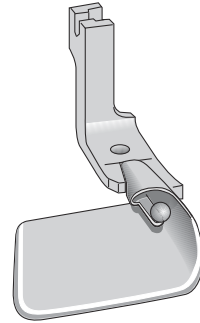

Sizes Details

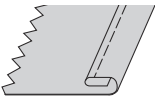

C = Needle
W = Hem size

Part No.	W	Materials
H6010- $\frac{1}{16}$	1.6 mm	Extra Thin
H6010- $\frac{1}{8}$	3.2 mm	Thin
H6010- $\frac{3}{16}$	4.8 mm	Thin
H6010- $\frac{1}{4}$	6.4 mm	Thin

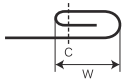

NOTE

- For straight stitch and gentle curving.
- This hemmers is for extra thin and thin materials.

Hem size

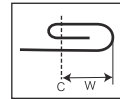
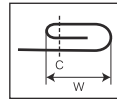

J Type Hemmer

A11S-13

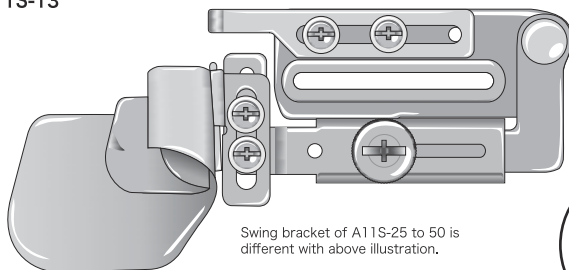

Swing bracket of A11S-25 to 50 is different with above illustration.

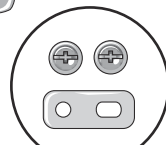

It is include with washer and screw.

Referred below table parts number of each sizes details.

Sizes Details

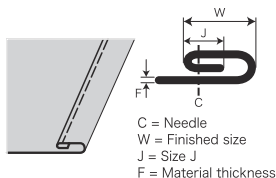

Part No.	W	J	F
A11S-6	6 mm	5.0 mm	0.5 mm
A11S-8	8 mm	6.0 mm	0.5 mm
A11S-10	10 mm	6.0 mm	0.5 mm
A11S-13	13 mm	7.0 mm	1.0 mm
A11S-15	15 mm	8.0 mm	1.5 mm
A11S-18	18 mm	9.0 mm	1.5 mm
A11S-20	20 mm	9.0 mm	1.5 mm
A11S-25	25 mm	9.0 mm	1.5 mm
A11S-30	30 mm	10.0 mm	1.5 mm
A11S-35	35 mm	10.0 mm	2.0 mm
A11S-40	40 mm	10.0 mm	2.0 mm
A11S-45	45 mm	10.0 mm	2.0 mm
A11S-50	50 mm	10.0 mm	2.0 mm

Parts Details

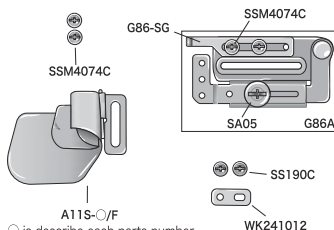

○ is describe each parts number at the left table.

Part No.	Description
A11S-○/F	A11S Hemmer
G86A	Swing bracket with second guide
G86-SG	Second guide
SA05	Screw (φ4 - L5)
SSM4074C	Screw (M4 × 0.7)
SS190C	Screw (φ4 - L8)
WK241012	Washer

Referred on page 80 for details of swing bracket A11S-25 to 50.

NOTE

- For straight edges and gentle outside curving.
- Feet for Folders & Hemmers are appropriate for stable sewing.
- Referred on page 77 for how to set hemmers.

Feet for Folders & Hemmers Applicable parts table

	6	8	10	13	15	18	20	25	30	35	40	45	50
SP3613		○	○										
SP3619				○	○	○	○						
SP3625								○	○	○	○	○	○
SP3811		○	○										
SP3819				○	○	○	○						
SP3825								○	○	○	○	○	○

Full Fold Hemmer

A110S-T8

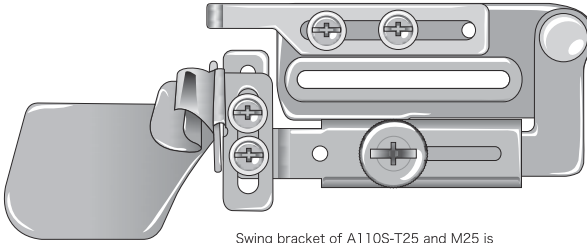

Swing bracket of A110S-T25 and M25 is different with above illustration.

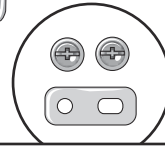

It is include with washer and screw.

Referred below table parts number of each sizes details.

Sizes Details

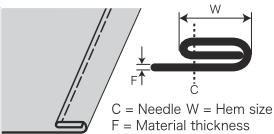

Part No.	W	F
A110S-T8	8 mm	0.5 mm
A110S-T10	10 mm	0.5 mm
A110S-T15	15 mm	1.5 mm
A110S-T20	20 mm	1.5 mm
A110S-T25	25 mm	1.5 mm
A110S-M10	10 mm	1.5 mm
A110S-M15	15 mm	2.0 mm
A110S-M20	20 mm	2.5 mm
A110S-M25	25 mm	2.5 mm

Parts Details

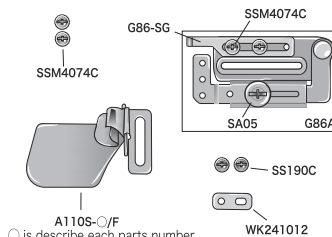

Part No.	Description
A110S-○/F	A110S Hemmer
G86A	Swing bracket with second guide
G86-SG	Second guide
SA05	Screw (3/64 - L5)
SSM4074C	Screw (M4 × 0.7)
SS190C	Screw (3/64 - L8)
WK241012	Washer

Referred on page 80 for details of swing bracket A110S-T25 and M25.

NOTE

- For straight edges and gentle outside curving.
- Feet for Folders & Hemmers are appropriate for stable sewing.
- Referred on page 77 for how to set hemmers.

Feet for Folders & Hemmers Applicable parts table

A110S-	T8	T10	T15	T20	T25	M10	M15	M20	M25
SP3613	○	○				○			
SP3619			○				○	○	
SP3625					○				○
SP3811	○	○				○			
SP3819			○	○			○	○	
SP3825					○				○

HEMMERS

SUISEI
OSAKA JAPAN

Hemmer (with Presser Foot and Leveling Plate)

A50-3

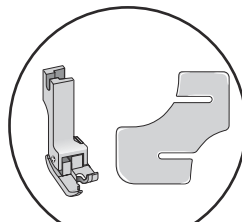
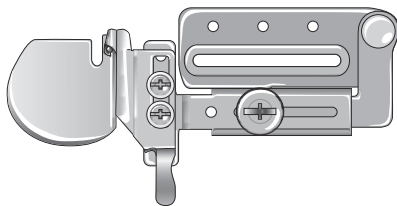

It is include with presser foot and leveling plate.

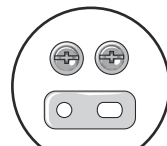

It is include with washer and screw.

Referred below table parts number of each sizes details.

Sizes Details

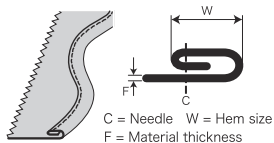

Part No.	W	F	Foot No.
A50-2.5	2.5 mm	0.2 mm	SHA25Z
A50-3	3.0 mm	0.3 mm	SHA30Z
A50-4	4.0 mm	0.5 mm	SHA40
A50-5	5.0 mm	0.5 mm	SHA50
A50-6	6.0 mm	0.5 mm	SHA60
A50-7	7.0 mm	0.6 mm	SHA70
A50-8	8.0 mm	0.6 mm	SHA80
A50-10	10.0 mm	1.0 mm	SHA100

Parts Details

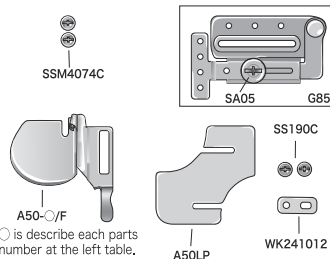

Part No.	Description
A50-○/F	A50 Hemmer
G85	Swing bracket
SA05	Screw (¼4 - L5)
SSM4074C	Screw (M4 × 0.7)
SS190C	Screw (¼4 - L8)
WK241012	Washer
A50LP	Leveling Plate

○ is describe each parts number at the left table.

NOTE

- Hemmer makes outstanding stableness on inside and outside curving operation.
- Referred on page 77 for how to set hemmers.

Hemmer for Slightly Heavy Materials (with Presser Foot and Leveling Plate)

A50HH-5

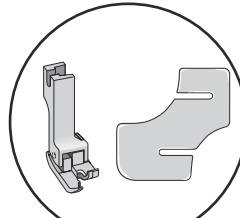
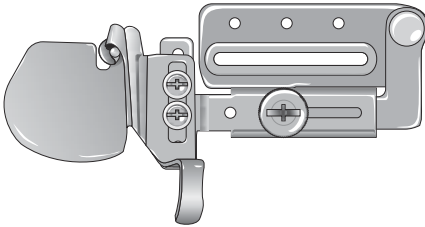

It is include with presser foot and leveling plate.

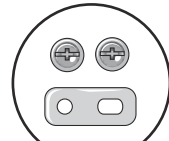

It is include with washer and screw.

Referred below table parts number of each sizes details.

Sizes Details

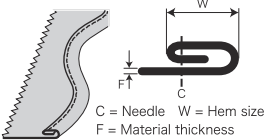

Part No.	W	F	Foot No.
A50HH-4	4.0 mm	1.0 mm	SHA40
A50HH-5	5.0 mm	1.0 mm	SHA50
A50HH-6	6.0 mm	1.3 mm	SHA60
A50HH-7	7.0 mm	1.3 mm	SHA70

Parts Details

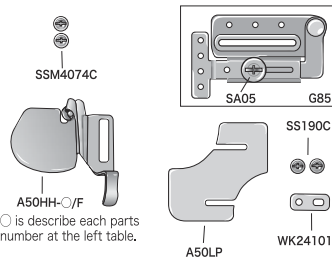

Part No.	Description
A50HH-○/F	A50HH Hemmer
G85	Swing bracket
SA05	Screw (3/16 - L5)
SSM4074C	Screw (M4 × 0.7)
SS190C	Screw (3/16 - L8)
WK241012	Washer
A50LP	Leveling Plate

NOTE

- Hemmer makes outstanding stableness on inside and outside curving operation.
- Referred on page 77 for how to set hemmers.

Latch Hemmer

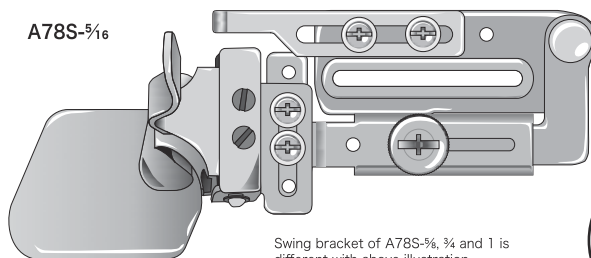

Swing bracket of A78S- $\frac{5}{16}$, $\frac{3}{4}$ and 1 is different with above illustration.

It is include with washer and screw.

Referred below table parts number of each sizes details.

Sizes Details

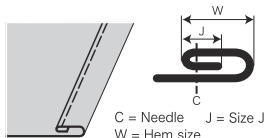

Part No.	W	J
A78S- $\frac{1}{4}$	6.4 mm	4.0 mm
A78S- $\frac{5}{16}$	8.0 mm	4.0 mm
A78S- $\frac{3}{8}$	9.5 mm	5.0 mm
A78S- $\frac{1}{2}$	12.7 mm	6.0 mm
A78S- $\frac{5}{8}$	15.9 mm	7.0 mm
A78S- $\frac{3}{4}$	19.0 mm	8.0 mm
A78S-1	25.4 mm	9.0 mm

Parts Details

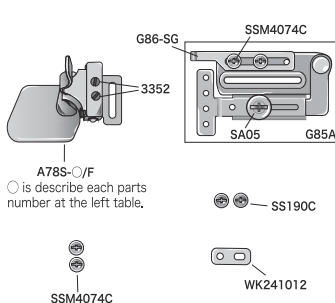

Part No.	Description
A78S-0/F	A78S Hemmer
G85A	Swing bracket with second guide
G86-SG	Second guide
SA05	Screw ($\frac{3}{64}$ - L5)
SSM4074C	Screw (M4 \times 0.7)
SS190C	Screw ($\frac{3}{64}$ - L8)
WK241012	Washer
3352	Screw ($\frac{3}{32}$ - 56)

Referred on page 80 for details of swing bracket A78S- $\frac{5}{16}$, $\frac{3}{4}$ and 1.

NOTE

- For straight edges and gentle outside curving.
- For medium or heavy materials
- Referred on page 77 for how to set hemmers.

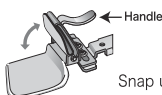

Snap up the folder by pressing on handle.

Latch Elastic Hemmer

A43L-20

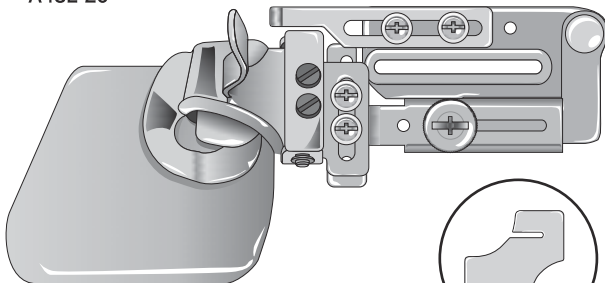

It is include with leveling plate.

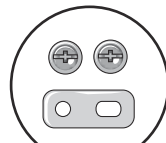

It is include with washer and screw.

Referred below table parts number of each sizes details.

Sizes Details

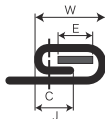
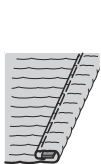

C = Needle
W = Hem size
J = Size J
E = Elastic size

Part No.	W	J	E
A43L-16	16 mm	7.0 mm	7.0 mm
A43L-20	20 mm	8.0 mm	8.0 mm

Parts Details

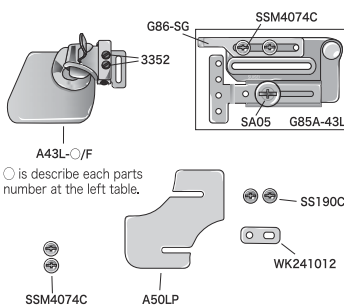

○ is describe each parts number at the left table.

Part No.	Description
A43L-○/F	A43L Hemmer
G85A-43L	Swing bracket with second guide
G86-SG	Second guide
SA05	Screw (M4 - L5)
SSM4074C	Screw (M4 × 0.7)
SS190C	Screw (M4 - L8)
WK241012	Washer
A50LP	Leveling Plate
3352	Screw (M2-56)

NOTE

- Do not use without elastic cord.
- Referred on page 77 for how to set hemmers.

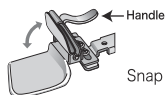

Snap up the folder by pressing on handle.

BRAID OR TAPE BINDERS

SUISEI
OSAKA JAPAN

Braid or Tape Binder

A4S-20

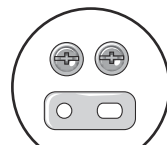
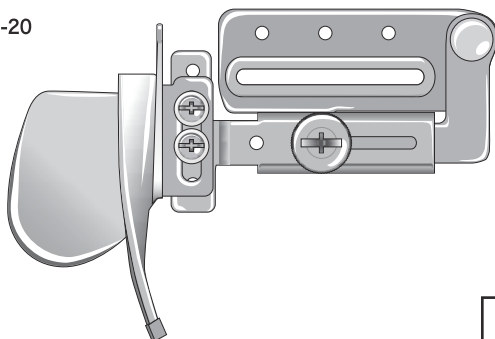

It is include with washer and screw.

Referred below table parts number of each sizes details.

Sizes Details

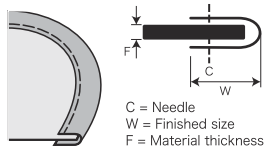

Part No.	T	W	F
A4S-10	10 mm	4.5 mm	1.0 mm
A4S-13	13 mm	6.0 mm	1.5 mm
A4S-16	16 mm	7.5 mm	1.5 mm
A4S-20	20 mm	9.0 mm	2.0 mm
A4S-22	22 mm	10.5 mm	2.0 mm
A4S-25	25 mm	12.0 mm	2.5 mm

T = Bias Tape Size

Parts Details

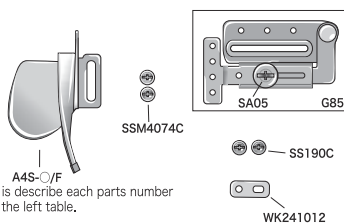

Part No.	Description
A4S-○/F	A4S Binder
G85	Swing bracket
SA05	Screw ($\frac{3}{16}$ - L5)
SSM4074C	Screw (M4 × 0.7)
SS190C	Screw ($\frac{3}{16}$ - L8)
WK241012	Washer

NOTE

- For straight edges and outside curving.
- Referred on page 77 for how to set binders.

⚠ CAUTION

The contents in above table may be different from fact and depend on material thickness or elasticity of tape. Please use as a measure of size.

BRAID OR TAPE BINDERS

SUISEI
OSAKA JAPAN

Braid or Tape Binder for Heavy Materials

A4S-20H

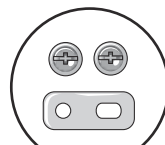
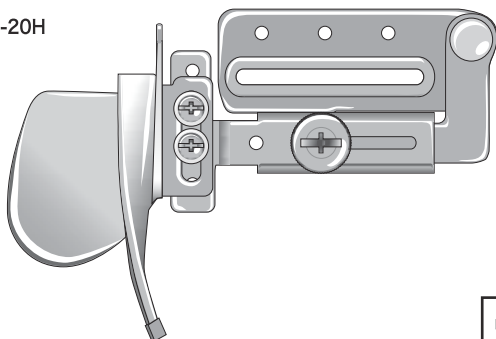

It is include with washer and screw.

Referred below table parts number of each sizes details.

Sizes Details

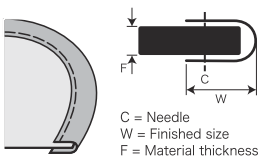

Part No.	T	W	F
A4S-18MH	18 mm	7.5 mm	3.0 mm
A4S-20H	20 mm	7.8 mm	4.5 mm
A4S-20XH	20 mm	7.5 mm	5.0 mm
A4S-25H	25 mm	10.3 mm	4.5 mm
A4S-25XH	25 mm	10.0 mm	5.0 mm

T = Bias Tape Size

Parts Details

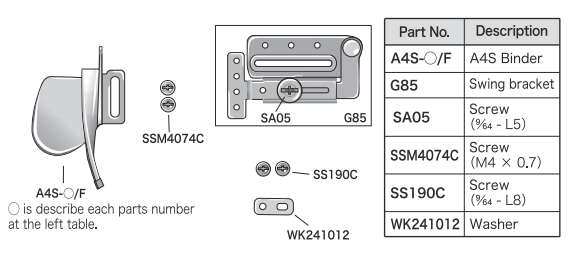

Part No.	Description
A4S-○/F	A4S Binder
G85	Swing bracket
SA05	Screw ($\frac{1}{4}$ " - L5)
SSM4074C	Screw (M4 × 0.7)
SS190C	Screw ($\frac{1}{4}$ " - L8)
WK241012	Washer

NOTE

- For straight edges and outside curving.
- Referred on page 77 for how to set binders.

⚠ CAUTION

The contents in above table may be different from fact and depend on material thickness or elasticity of tape. Please use as a measure of size.

Single Upturn Feller

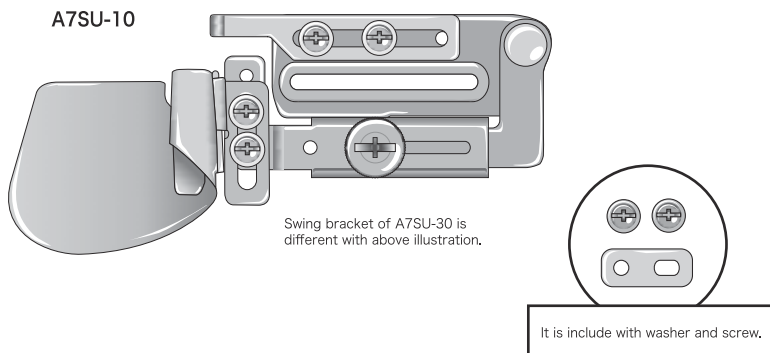

Referred below table parts number of each sizes details.

Sizes Details

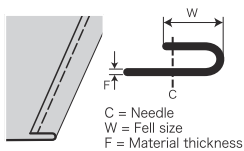

Part No.	W	F
A7SU-5	5 mm	1.0 mm
A7SU-6	6 mm	1.0 mm
A7SU-8	8 mm	1.0 mm
A7SU-10	10 mm	1.5 mm
A7SU-13	13 mm	1.5 mm
A7SU-15	15 mm	1.5 mm
A7SU-18	18 mm	1.5 mm
A7SU-20	20 mm	1.5 mm
A7SU-25	25 mm	1.5 mm
A7SU-30	30 mm	1.5 mm

Parts Details

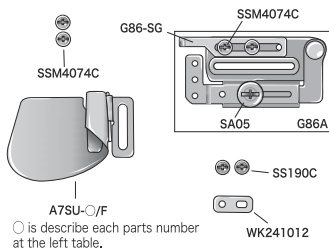

Part No.	Description
A7SU-○/F	A7SU Feller
G86A	Swing bracket with second guide
G86-SG	Second guide
SA05	Screw (5/64 - L5)
SSM4074C	Screw (M4 × 0.7)
SS190C	Screw (5/64 - L8)
WK241012	Washer

Referred on page 80 for details of swing bracket A7SU-30.

NOTE

- For straight edges and gentle outside curving.
- Referred on page 77 for how to set fellers.

Single Downturn Feller

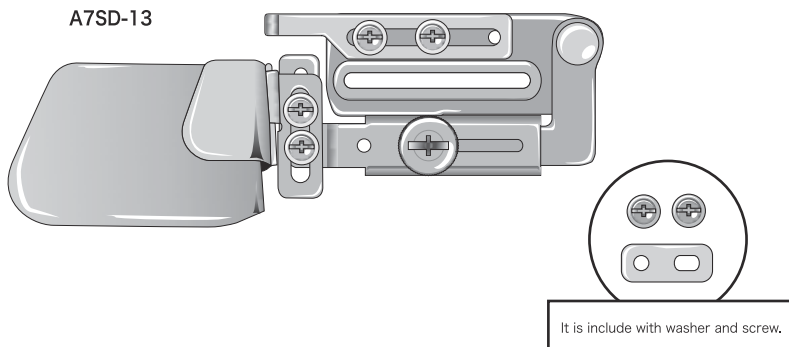

Referred below table parts number of each sizes details.

Sizes Details

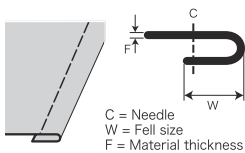

Part No.	W	F
A7SD-5	5 mm	1.0 mm
A7SD-6	6 mm	1.0 mm
A7SD-8	8 mm	1.0 mm
A7SD-10	10 mm	1.5 mm
A7SD-13	13 mm	1.5 mm
A7SD-15	15 mm	1.5 mm
A7SD-18	18 mm	1.5 mm
A7SD-20	20 mm	1.5 mm

Parts Details

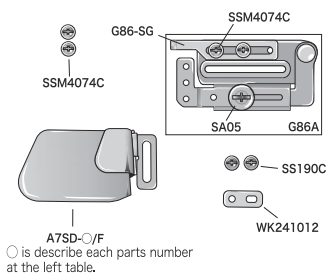

Part No.	Description
A7SD-○/F	A7SD Feller
G86A	Swing bracket with second guide
G86-SG	Second guide
SA05	Screw (3/64 - L5)
SSM4074C	Screw (M4 × 0.7)
SS190C	Screw (3/64 - L8)
WK241012	Washer

NOTE

- For straight edges and gentle outside curving.
- Referred on page 77 for how to set fellers.

Top Stitch Feller Feet

H5017- $\frac{3}{16}$



H5019- $\frac{3}{16}$

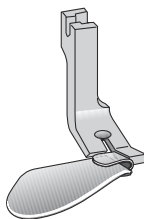

H5019- $\frac{1}{4}$

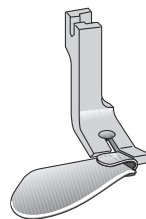

H5019R- $\frac{3}{16}$

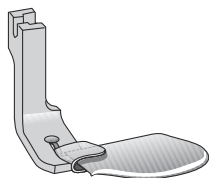

H5019R- $\frac{1}{4}$

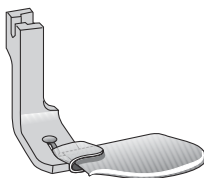

H5020- $\frac{3}{16}$

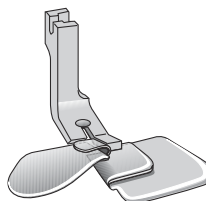

H5020- $\frac{1}{4}$

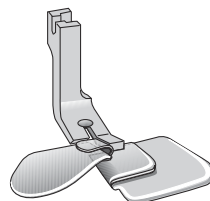

Sizes Details

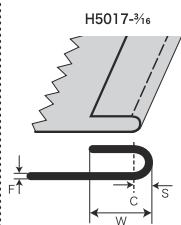

H5017- $\frac{3}{16}$

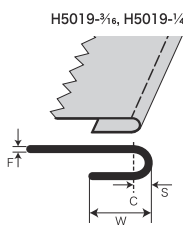

H5019- $\frac{3}{16}$, H5019- $\frac{1}{4}$

C = Needle
W = Fell size
S = Stitch margin
F = Material thickness

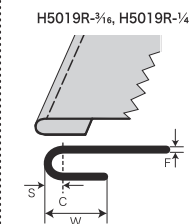

H5019R- $\frac{3}{16}$, H5019R- $\frac{1}{4}$

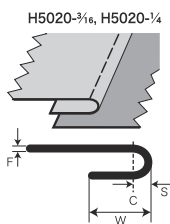

H5020- $\frac{3}{16}$, H5020- $\frac{1}{4}$

Part No.	W	S	F
H5017- $\frac{3}{16}$	4.8 mm	1.0 mm	1.0 mm
H5019- $\frac{3}{16}$	4.8 mm	1.0 mm	0.5 mm
H5019- $\frac{1}{4}$	6.4 mm	1.0 mm	0.5 mm
H5019R- $\frac{3}{16}$	4.8 mm	1.0 mm	0.5 mm
H5019R- $\frac{1}{4}$	6.4 mm	1.0 mm	0.5 mm
H5020- $\frac{3}{16}$	4.8 mm	1.0 mm	1.0 mm
H5020- $\frac{1}{4}$	6.4 mm	1.0 mm	1.0 mm

● FOR SPECIAL MACHINES

SUISEI
OSAKA JAPAN

Swing Bracket for Special Machines

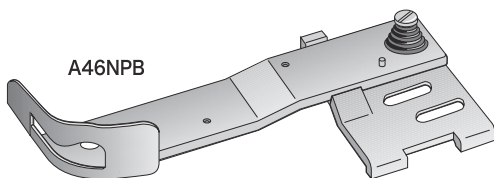

A46NPB

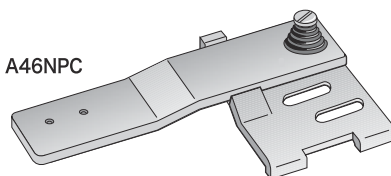

A46NPC

Parts Details

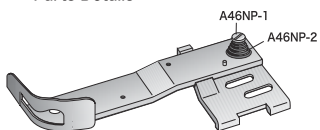

Part No.	Description
A46NP-1	Screw (M5 × 0.8)
A46NP-2	Spiral spring

For A46NPB & A46NPC

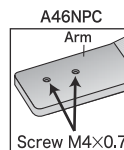
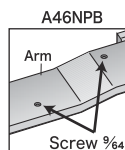

HOW TO SETTING

Without leveling plate

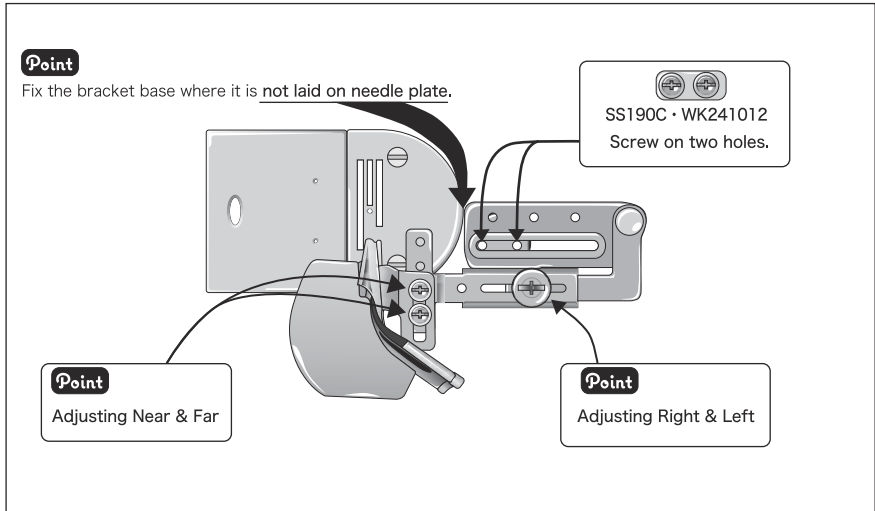

Applicable series : A5S series, A5BS series, A1S series, A9S series, A2S series, A11S series
A110S series, A78S series, A4S series, A7SU series, A7SD series

With leveling plate

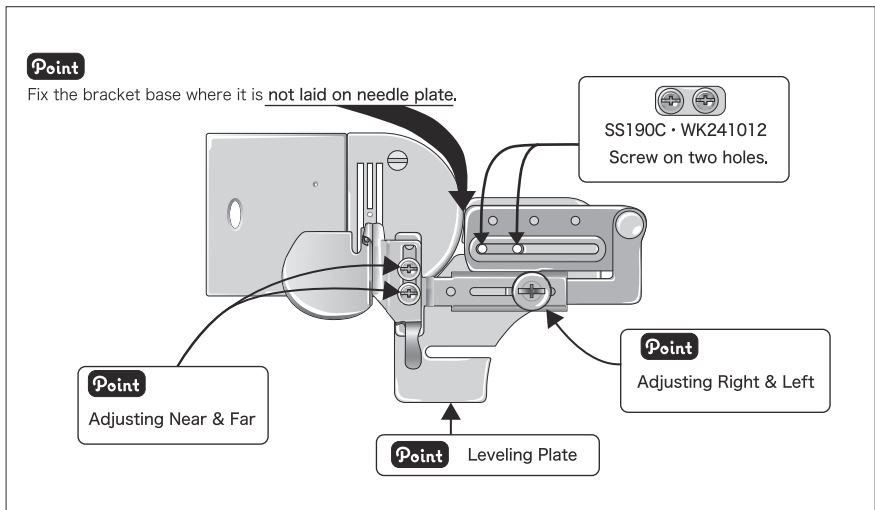

Applicable series : A5S-30, A5S-40, A50 series, A50HH series, A43L series

GAUGES and ACCESSORIES

SUISEI®
OSAKA JAPAN

GAUGES

SUISEI
OSAKA JAPAN

T Gauge • Swing Gauge

G1

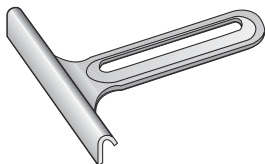

G7E

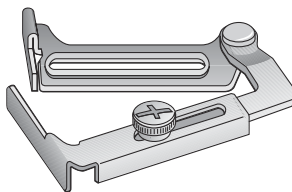

Parts Details

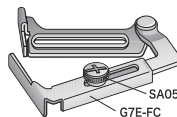

Part No.	Description
G7E-FC	G7E Cover
SA05	Screw

Strong Magnetic Gauge

G20Z



NOTE

G20Z is SUISEI original structure.
Enable to strongly guiding to sew heavy material like denim.

CAUTION

Due to the strong magnet, Please keep it away from the people who use heart pace maker, as its magnet field affect on the function of pace maker.

Swing Brackets for Binders, Floders, Hemmers, and Fellers

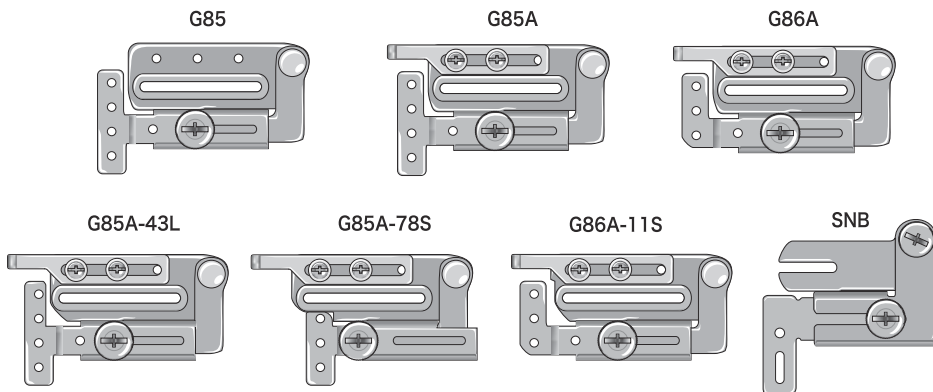

Swing bracket set list

Part No.	
A1S-20	G85
A1S-22	G85
A1S-24	G85
A1S-26	G85
A1S-28	G85
A1S-30	G85
A1S-32	G85
A1S-36	G85
A1S-40	G85
A11S-6	G86A
A11S-8	G86A
A11S-10	G86A
A11S-13	G86A
A11S-15	G86A
A11S-18	G86A
A11S-20	G86A
A11S-25	G86A-11S
A11S-30	SNB
A11S-35	SNB
A11S-40	SNB
A11S-45	SNB
A11S-50	SNB
A110S-T8	G86A
A110S-T10	G86A
A110S-T15	G86A
A110S-T20	G86A
A110S-T25	G86A-11S
A110S-M10	G86A

Part No.	
A110S-M15	G86A
A110S-M20	G86A
A110S-M25	G86A-11S
A2S-20	G85
A2S-22	G85
A2S-24	G85
A2S-26	G85
A2S-28	G85
A2S-30	G85
A2S-32	G85
A4S-10	G85
A4S-13	G85
A4S-16	G85
A4S-20	G85
A4S-22	G85
A4S-25	G85
A4S-18MH	G85
A4S-20H	G85
A4S-20XH	G85
A4S-25H	G85
A4S-25XH	G85
A43L-16	A85A-43L
A43L-20	A85A-43L
A5S-5	G85A
A5S-8	G85A
A5S-10	G85A
A5S-12	G85A
A5S-15	G85A

Part No.	
A5S-18	G85A
A5S-20	G85A
A5S-24	G85A-43L
A5S-30	SNB
A5S-40	SNB
A5BS-8	G85A
A5BS-10	G85A
A5BS-12	G85A
A5BS-15	G85A
A5BS-18	G85A
A5BS-20	G85A
A5BS-24	G85A-43L
A50-2.5	G85
A50-3	G85
A50-4	G85
A50-5	G85
A50-6	G85
A50-7	G85
A50-8	G85
A50-10	G85
A50HH-4	G85
A50HH-5	G85
A50HH-6	G85
A50HH-7	G85
A78S- $\frac{1}{4}$	G85A
A78S- $\frac{1}{2}$	G85A
A78S- $\frac{3}{8}$	G85A
A78S- $\frac{1}{2}$	G85A

Part No.	
A78S- $\frac{5}{8}$	G85A-78S
A78S- $\frac{3}{4}$	G85A-78S
A78S-1	G85A-78S
A7SU-5	G86A
A7SU-6	G86A
A7SU-8	G86A
A7SU-10	G86A
A7SU-13	G86A
A7SU-15	G86A
A7SU-18	G86A
A7SU-20	G86A
A7SU-25	G86A
A7SU-30	G85A-78S
A7SD-5	G86A
A7SD-6	G86A
A7SD-8	G86A
A7SD-10	G86A
A7SD-13	G86A
A7SD-15	G86A
A7SD-18	G86A
A7SD-20	G86A
A9S-25	G85
A9S-28	G85
A9S-32	G85
A9S-38	G85

● NEEDLE PLATES

SUISEI
OSAKA JAPAN

Needle Plates for Right Angle Bias Binders

A10N-222

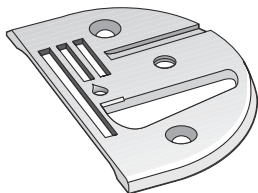

Parts Details

Part No.	Binder No.
A10N-160	A10S-16, A10S-18, A10S-20
A10N-222	A10S-22, A10S-24, A10S-26 A10S-28, A10S-30 A10H-24, A10H-26, A10H-28 A10H-30
A10N-360	A10S-32, A10S-36, A10S-40 A10H-32, A10H-36, A10H-40
A10N-450	A10S-45, A10S-50 A10H-45, A10H-50

Referred on A10S about A10C and A10CW.
Referred on A10H about A10HC and A10HCW.

Needle Plate for 20002 Feed Dog

12442

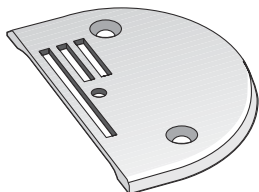

NOTE

12442 Needle plate is for 20002 feed dog.

Feed Dog for Right Angle Bias Binders

20002

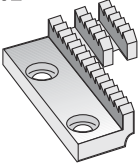

NOTE _____

20002 feed dog is for right angle bias binders.

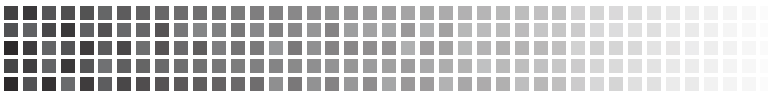

SCREWS & SPRINGS

SUISEI
OSAKA JAPAN

Screws for Feet

CPS07



CPS10



CPS13



CPS16



CPS19



Sizes Details

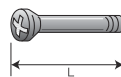

L = Screw length

Part No.	L
CPS07	7.5 mm
CPS10	10.8 mm
CPS13	13.3 mm
CPS16	16.3 mm
CPS19	19.3 mm

All screws is M2.

Screws for Attachments

SA05

(Old Part No. SA5)



SA078

(Old Part No. SA)



Sizes Details



L = Thread length

Part No.	L
SA05	5.0 mm
SA078	7.8 mm

All screws is 3/4.

Springs for Feet

B20



B25

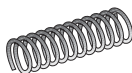

B30U

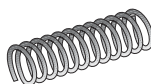

Sizes Details

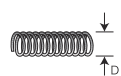

D = Spring diameter

Part No.	D
B20	2.0 mm
B25	2.5 mm
B30U	3.0 mm

Standard Tape Reel Stand

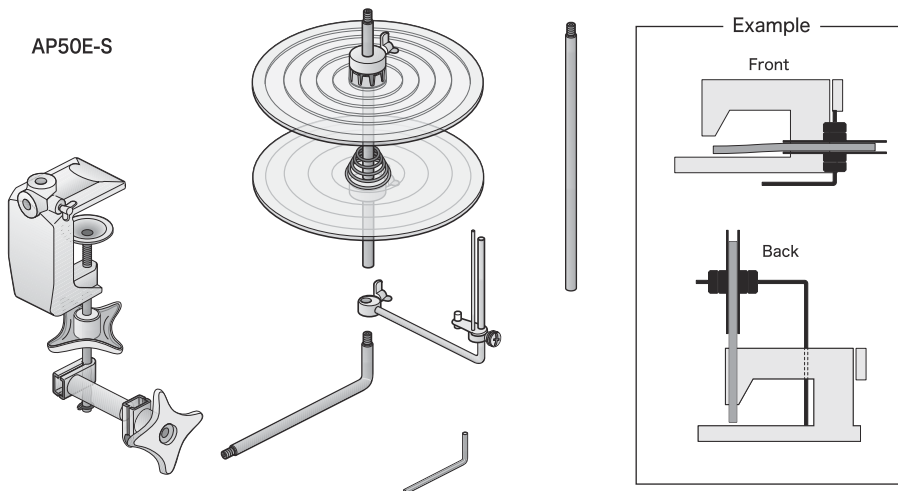

- Smooth rotation solves uneven feeding of tape in binding.
- Semitransparent plates show an amount of remaining tape.

Parts Details

Part No.	Description	Qty
AP50E-1243E	Vice and joint asm.	1
AP50E-5E	L rod	1
AP50E-7	Wing screw	4
AP50E-8	Taper spring	1
AP50E-17	Connecting rod	2
AP50E-20	Bias tape guide complete	1
AP50E-23	Plastic plate	2
KTL40	L - wrench (4.0mm)	1

BINDING & TAPE REEL STANDS

SUISEI
OSAKA JAPAN

Tape Reel Stand for Knit Tape

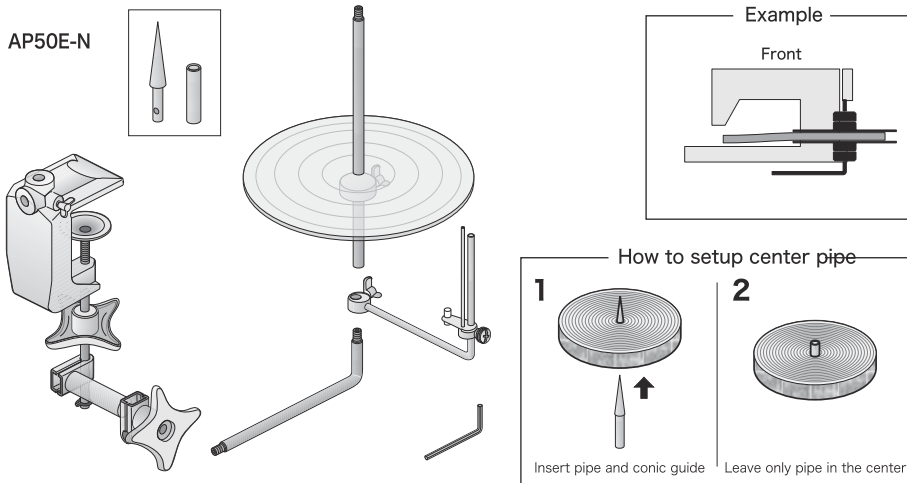

- Smooth rotation solves uneven feeding of tape in binding.
- Semitransparent plates show an amount of remaining tape.

Parts Details

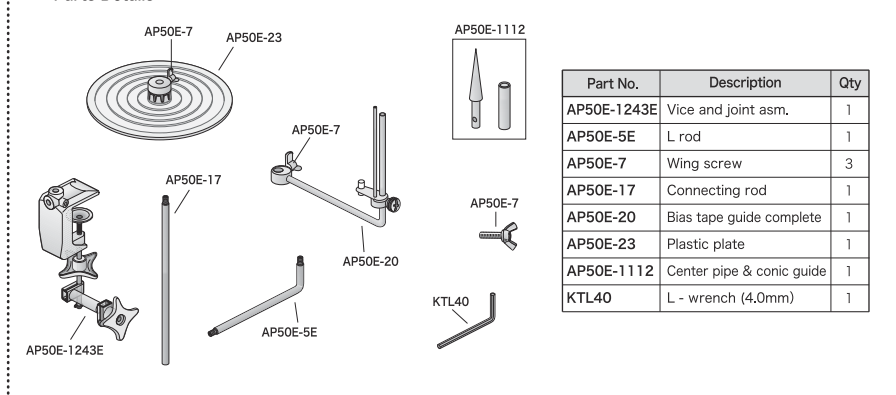

Tape Reel Stand Extra Set

AP50E-AW

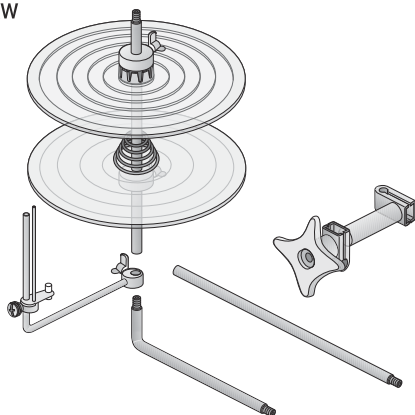

Parts Details

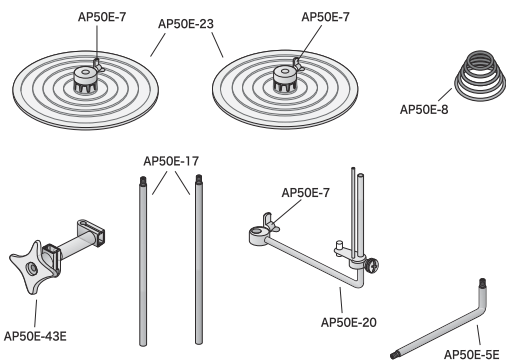

Part No.	Description	Qty
AP50E-43E	Joint complete	1
AP50E-5E	L rod	1
AP50E-7	Wing screw	3
AP50E-8	Taper spring	1
AP50E-17	Connecting rod	2
AP50E-20	Bias tape guide complete	1
AP50E-23	Plastic plate	2

ROLLERS

SUISEI
OSAKA JAPAN

Urethane Rollers & Steel Rollers

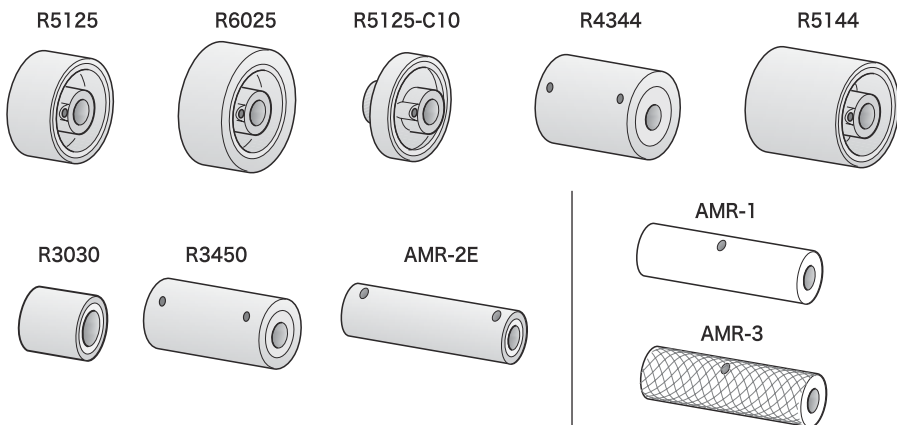

※ AMR-1 and AMR-3 is steel rollers

Sizes Details

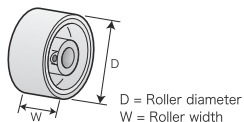

Part No.	D	W
R5125	51 mm	25 mm
R6025	60 mm	25 mm
R4344	43 mm	44 mm
R5144	51 mm	44 mm
R3030	30 mm	30 mm
R3450	34 mm	50 mm
R5125-C10	51 mm	25(10) mm
AMR-2E	25.5 mm	76 mm
AMR-1	25.5 mm	77 mm
AMR-3	25.5 mm	77 mm

R5125-C10

Roller width is 25mm.

Urethane width is 10mm in the ().

Parts Details

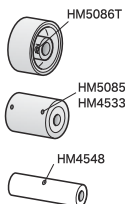

Part No.	Description	Roller No.
HM5086T	Screw for rollers (M5 × 0.8)	R5125, R6025 R5025-C10, R5144
HM5085	Screw for rollers (M5 × 0.8)	R4344, R3450
HM4533	Screw for rollers (φ6)	AMR-2E
HM4548	Screw for rollers (φ6)	AMR-1, AMR-3

Tape Guide for Binders

TG-40

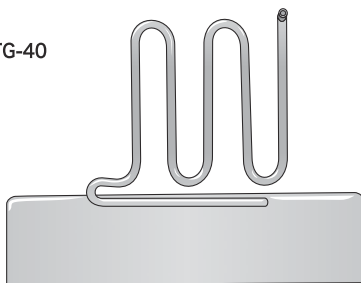

Sizes Details



T = Max tape size

Part No.	T
TG-40	40 mm
TG-60	60 mm

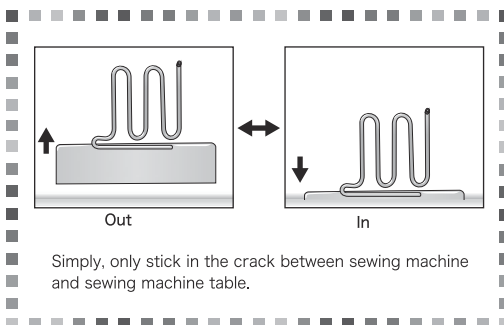

ACCESSORIES

Regular Cloth Puller

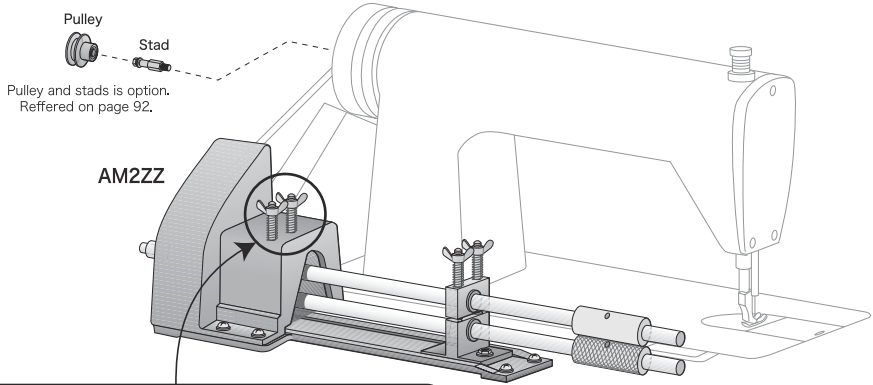

If interlocking of the gears is wrong for reasons of abration of gear, shafts or nylon bushes, please tighten and both wing nuts at input side.

Parts Details

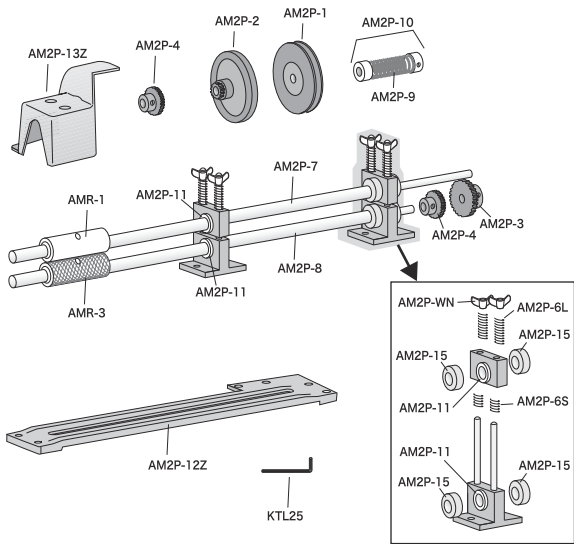

Part No.	Description	Qty
AM2P-1	V pulley	1
AM2P-2	Clutch wheel with gear	1
AM2P-3	Large gear (40mm)	1
AM2P-4	Medium gear (28mm)	2
AM2P-6L	Tension spring (Long)	4
AM2P-6S	Tension spring (Short)	4
AM2P-7	Upper shaft	1
AM2P-8	Lower shaft	1
AM2P-9	Clutch spring	1
AM2P-10	Clutch spring complete	1
AM2P-11	Nylon bushing	4
AM2P-12Z	Mount base	1
AM2P-13Z	Gear cover	1
AM2P-15	Collar	4
AM2P-WN	Wing nut	4
KTL25	L - wrench (2,5mm)	1
AMR-1	Steel plane roller	1
AMR-3	Steel knurled roller	1

Referred on page 87 for AMR-1, AMR-3

Pulley and Stads

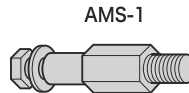
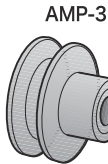

Pulley

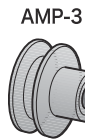

Stads
Regular Type

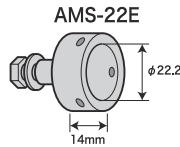
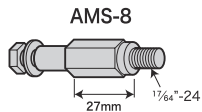
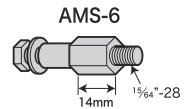
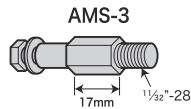
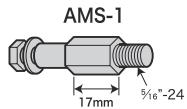

Stads
For Automatic
Thread Trimmer

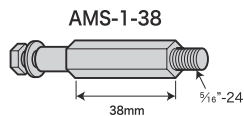
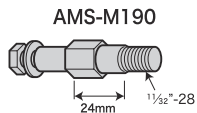

Cap Screw

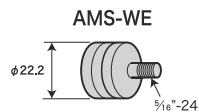
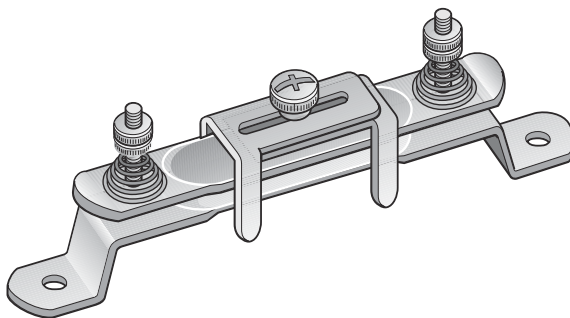
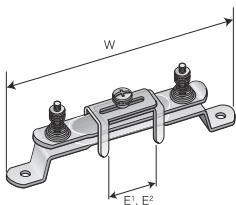

Table Type Elastic Tension Bracket



Sizes Details



W = Width
E¹ = Min width
E² = Max width

Part No.	W	E ¹	E ²
AP11E	153 mm	3 mm	43 mm

Parts Details

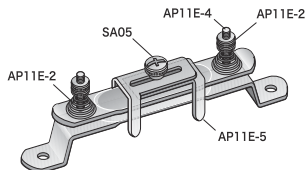

Part No.	Description
AP11E-2	Spiral spring
AP11E-3	Adjustable nut
AP11E-4	Adjustable load
AP11E-5	Adjustable guide
SA05	screw

ACCESSORIES

SUISEI
OSAKA JAPAN

Finger Guard Set for One Needle Lock Stitch Machines (Includes L- Wrench)

SFG1

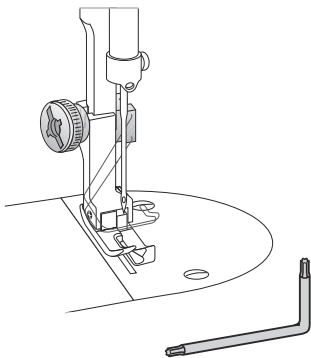

Parts number SFG1NW is without L-wrench.

Parts Details

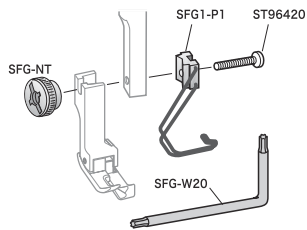

Part No.	Description
SFG1-P1	Guard wire complete
SFG-NT	Thumb nut
SFG-W20	L - wrench
ST96420	Screw (3/64 - L20)

Finger Guard Set for One Needle Lock Stitch Machines for PFAFF (Includes L- Wrench)

SFG1PF

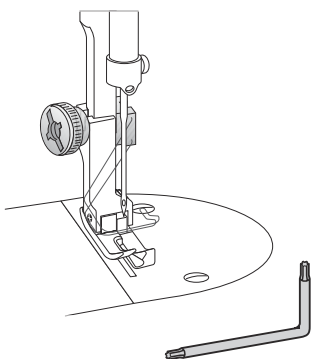

Parts number SFG1NWPf is without L-wrench.

Parts Details

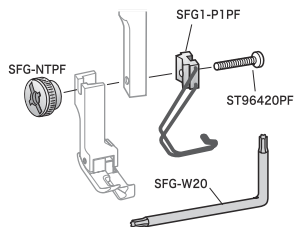

Part No.	Description
SFG1-P1PF	Guard wire complete
SFG-NTPF	Thumb nut
SFG-W20	L - wrench
ST96420PF	Screw (M4)

INDEX

A

A1S-20	61
A1S-22	61
A1S-24	61
A1S-26	61
A1S-28	61
A1S-30	61
A1S-32	61
A1S-36	61
A1S-40	61
A10C-16	58
A10C-18	58
A10C-20	58
A10C-22	58
A10C-24	58
A10C-26	58
A10C-28	58
A10C-30	58
A10C-32	58
A10C-36	58
A10C-40	58
A10C-45	58
A10C-50	58
A10CW-18	58
A10CW-20	58
A10CW-22	58
A10CW-24	58
A10CW-26	58
A10CW-28	58
A10CW-30	58
A10CW-32	58
A10CW-36	58
A10CW-40	58
A10CW-45	58
A10CW-50	58
A10H-24	59
A10H-26	59
A10H-28	59
A10H-30	59
A10H-32	59
A10H-36	59
A10H-40	59
A10H-45	59
A10H-50	59
A10HC-24	59
A10HC-26	59
A10HC-28	59
A10HC-30	59
A10HC-32	59
A10HC-36	59
A10HC-40	59
A10HC-45	59
A10HC-50	59
A10HCW-24	59
A10HCW-26	59
A10HCW-28	59
A10HCW-30	59
A10HCW-32	59
A10HCW-36	59
A10HCW-40	59
A10HCW-45	59
A10HCW-50	59
A10HE	60
A10N-160	60, 81
A10N-222	60, 81
A10N-360	60, 81
A10N-450	60, 81
A10S-16	58
A10S-18	58
A10S-20	58
A10S-22	58
A10S-24	58
A10S-26	58
A10S-28	58
A10S-30	58
A10S-32	58
A10S-36	58
A10S-40	58
A10S-45	58
A10S-50	58
A10SS	60
A11S-6	65
A11S-8	65
A11S-10	65
A11S-13	65
A11S-15	65
A11S-18	65
A11S-20	65
A11S-25	65
A11S-30	65
A11S-35	65
A11S-40	65
A11S-45	65
A11S-50	65
A110S-M10	66
A110S-M15	66
A110S-M20	66
A110S-M25	66
A110S-T8	66
A110S-T10	66
A110S-T15	66
A110S-T20	66
A110S-T25	66
A18	24, 53
A18-PA	22, 24, 25, 53, 54, 55
A2S-20	63
A2S-22	63
A2S-24	63
A2S-26	63
A2S-28	63
A2S-30	63
A2S-32	63
A20-18	22, 54
A20-20	22, 54
A20-22	22, 54
A20-24	22, 54
A20-26	22, 54
A20-28	22, 54
A21-3	25, 55
A21-4	25, 55
A21-5	25, 55
A21-6,5	25, 55
A255	24, 53
A255-NT	24, 53
A255-SG	24, 53
A255-TA	24, 53
A255P	24, 53
A4S-10	71
A4S-13	71
A4S-16	71
A4S-20	71
A4S-22	71
A4S-25	71
A4S-18MH	72
A4S-20H	72
A4S-20XH	72
A4S-25H	72
A4S-25XH	72
A43L-16	70
A43L-20	70
A46NP-1	76
A46NP-2	76
A46NPB	76
A46NPC	76
A5S-5	56
A5S-8	56
A5S-10	56
A5S-12	56
A5S-15	56
A5S-18	56
A5S-20	56
A5S-24	56
A5S-30	56
A5S-40	56
A5BS-5	57
A5BS-8	57
A5BS-10	57
A5BS-12	57
A5BS-15	57
A5BS-18	57
A5BS-20	57
A5BS-24	57
A50-2,5	67
A50-3	67
A50-4	67
A50-5	67
A50-6	67
A50-7	67
A50-8	67
A50-10	67
A50HH-4	68
A50HH-5	68
A50HH-6	68
A50HH-7	68
A50LP	67, 68, 70
A78S-¼	69
A78S-⅓	69
A78S-½	69

A78S- $\frac{5}{8}$	69
A78S- $\frac{3}{4}$	69
A78S-1	69
A7SD-5	74
A7SD-6	74
A7SD-8	74
A7SD-10	74
A7SD-13	74
A7SD-15	74
A7SD-18	74
A7SD-20	74
A7SU-5	73
A7SU-6	73
A7SU-8	73
A7SU-10	73
A7SU-13	73
A7SU-15	73
A7SU-18	73
A7SU-20	73
A7SU-25	73
A7SU-30	73
A9S-25	62
A9S-28	62
A9S-32	62
A9S-38	62
AM2P-1	89
AM2P-2	89
AM2P-3	89
AM2P-4	89
AM2P-6L	89
AM2P-6S	89
AM2P-7	89
AM2P-8	89
AM2P-9	89
AM2P-10	89
AM2P-11	89
AM2P-12Z	89
AM2P-13Z	89
AM2P-15	89
AM2P-WN	89
AM2ZZ	89
AMP-3	89, 90
AMR-1	87, 89
AMR-2E	87
AMR-3	87, 89
AMS-1	90
AMS-1-38	90
AMS-22E	90
AMS-3	90
AMS-6	90
AMS-8	90
AMS-M190	90
AMS-WE	90
AP11E	91
AP11E-2	91
AP11E-3	91
AP11E-4	91
AP11E-5	91
AP50E-5E	84, 85, 86
AP50E-7	84, 85, 86

AP50E-8	84, 86
AP50E-1112	85
AP50E-1243E	84, 85
AP50E-43E	86
AP50E-17	84, 85, 86
AP50E-20	84, 85, 86
AP50E-23	84, 85, 86
AP50E-N	85
AP50E-S	84
AP50E-AW	86

B

B16	48, 49, 50
B20	83
B25	7, 83
B30U	83

C

C5	7
C6	7
CPS07	83
CPS10	83
CPS13	83
CPS16	83
CPS19	83
CL70	7
CL80	7

G

G1	79
G20Z	79
G7E	79
G7E-FC	79
G85	80
G85A	80
G85A-43L	80
G85A-78S	80
G86-SG	80
G86A	80
G86A-11S	80

H

H5017- $\frac{3}{16}$	40, 75
H5019- $\frac{3}{16}$	40, 75
H5019- $\frac{1}{4}$	40, 75
H5019R- $\frac{3}{16}$	40, 75
H5019R- $\frac{1}{4}$	40, 75
H5020- $\frac{3}{16}$	40, 75
H5020- $\frac{1}{4}$	40, 75
H6010- $\frac{1}{16}$	39, 64
H6010- $\frac{1}{8}$	39, 64
H6010- $\frac{3}{16}$	39, 64
H6010- $\frac{1}{4}$	39, 64
HM4533	87

HM4548	87
HM5085	87
HM5086T	87

K

KTL25	89
KTL40	84, 85

M

M30515RL	10
M3054R	24, 53

P

P01	2
P01W	2
P10	2
P11	2
P115	2
P12	2
P13	2
P14	2
P15	2
P16	2
P18	2
P112B- $\frac{1}{8}$	48
P112B- $\frac{3}{16}$	48
P112B- $\frac{1}{4}$	48
P112B- $\frac{3}{8}$	48
P112B- $\frac{1}{2}$	48
P112J- $\frac{3}{16}$	50
P112J- $\frac{1}{4}$	50
P112J- $\frac{3}{8}$	50
P112J- $\frac{1}{2}$	50
P112M- $\frac{3}{16}$	49
P112M- $\frac{1}{4}$	49
P112M- $\frac{3}{8}$	49
P112M- $\frac{1}{2}$	49
P3	12
P3C	12
P3CS	12
P301	14
P301N	14
P31	15
P311N	15
P37	21
P37M	21
P37W	21
P375	47
P375B	47
P375BL	47
P39	25
P5	11
P5W	11
P50	11
P50M	11

INDEX

P50H	11
P69D- $\frac{1}{4}$	21
P69D- $\frac{3}{16}$	21
P69D- $\frac{1}{2}$	21
P69L- $\frac{1}{8}$	20
P69L- $\frac{3}{16}$	20
P69L- $\frac{1}{4}$	20
P69L- $\frac{3}{8}$	20
P69R- $\frac{1}{4}$	20
P69R- $\frac{3}{16}$	20
P69R- $\frac{1}{2}$	20
P69R- $\frac{3}{8}$	20
P723	3
P723NF	43
P723-CS	3, 43
P723-GL	3, 43
P723-GR	3, 43
P723-SS	3, 43

R

R3030	87
R3450	87
R4344	87
R5125	87
R5125-C10	87
R5144	87
R6025	87

S

S0050N	44
S1060	16
S1560	16
S2060N	44
S2525	12, 17
S2525N	44
S2525NN	44
S3030	12, 17
S3030N	44
S351NF	44
S4040	17
S4040V	17
S5000N	44
S5050	17
S5050N	44
S5050V	17
S6010	16
S6015	16
S6020N	44
S6060V	17
S6565	18
S69LH-30	19
S69LH-50	19
S69RH-30	19
S69RH-50	19
S7070V	17
S955	10
S955KM	10

S955-S	10
SA05	83
SA078	83
SA40	27, 51
SA45	27, 51
SA55	27, 51
SA65	27, 51
SA75	27, 51
SA85	27, 51
SA95	27, 51
SA105	27, 51
SA130	27, 51
SA140	27, 51
SA150	27, 51
SA200	27, 51
SA250	27, 51
SAN40	45, 51
SAN45	45, 51
SAN55	45, 51
SAN65	45, 51
SAN75	45, 51
SAN85	45, 51
SAN95	45, 51
SAN105	45, 51
SAN130	45, 51
SAN140	45, 51
SAN150	45, 51
SAN200	45, 51
SAN250	45, 51
SC40	28, 51
SC45	28, 51
SC55	28, 51
SC65	28, 51
SC75	28, 51
SC85	28, 51
SC95	28, 51
SC105	28, 51
SCW45	29, 51
SCW55	29, 51
SCW65	29, 51
SCW75	29, 51
SCW85	29, 51
SCW95	29, 51
SCW105	29, 51
SD10	9
SD15	9
SD20	9
SD25	9
SD30	9
SDK15ND	13
SDK18ND	13
SDK-NGD	13
SFG1	92
SFG1PF	92
SFG1NW	92
SFG1NWP	92
SFG1-P1	92
SFG1-P1PF	92
SFG-NT	92
SFG-NTPF	92

SFG-W20	92
SG-P0	1, 2, 41
SG-P1	1, 41
SG-P1L	2, 41
SG-P2	1, 41
SG10	1
SG10L	2
SG15	1
SG15L	2
SG20	1
SG20L	2
SG30	1
SG30L	2
SG40	1
SG50	1
SG60	1
SG65	1
SG70	1
SG80	1
SG110	1
SG150	1
SG200	1
SGN10	41
SGN10L	41
SGN15	41
SGN15L	41
SGN20	41
SGN20L	41
SGN30	41
SGN30L	41
SGN40	41
SGN50	41
SGN60	41
SGN65	41
SGN70	41
SGN80	41
SHA25Z	30, 67
SHA30Z	30, 67
SHA40	30, 67, 68
SHA50	30, 67, 68
SHA60	30, 67, 68
SHA70	30, 67, 68
SHA80	30, 67
SHA100	30, 67
SL10	7
SL10N	8
SL10NF	42
SL15	7
SL15N	8
SL15NF	42
SL20	7
SL20NF	42
SL25	7
SL25NF	42
SL30	7
SL30NF	42
SL40	7
SL50	7
SL60	7
SLC10	8

SLC15	8
SLC20	8
SLC30	8
SNB	80
SP127	18
SP351	18
SP351KZ	18, 37
SP352	17
SP36	15, 38
SP360	12, 16
SP361	12, 16
SP3613	31, 65, 66
SP3619	31, 65, 66
SP3625	31, 65, 66
SP36L	14, 38
SP36LN	14, 38
SP36N	15, 38
SP3811	32, 56, 57, 65, 66
SP3819	32, 56, 57, 65, 66
SP3825	32, 56, 57, 65, 66
SP58N	18
SP60	26
SP62	26
SP63	26
SP64	26
SP65	26
SR10	4
SR10KZ	6, 36
SR10N	5
SR10NKZ	6, 36
SR10NF	42
SR15	4
SR15KZ	6, 36
SR15N	5
SR15NKZ	6, 36
SR15NF	42
SR20	4
SR20KZ	6, 36
SR20NF	42
SR25	4
SR25KZ	6, 36
SR25NF	42
SR30	4
SR30KZ	6, 36
SR30NF	42
SR40	4
SR40KZ	6, 36
SR50	4
SR50KZ	6, 36
SR60	4
SR60KZ	6, 36
SR65	4
SR65KZ	6, 36
SR70	4
SR80	4
SR100	4
SRC10	5
SRC15	5
SRC20	5
SRC30	5

SS190C	56-57, 61-63, 65-74
SSM4074C	56-57, 61-63, 65-74
ST350	33
ST350NF	35, 46
ST35CW	33
ST35CWNF	35, 46
ST35W	33
ST35WNF	35, 46
ST363	33
ST363C	33
ST363CNF	35, 46
ST363NF	35, 46
ST36LN	33
ST36N	33
ST96420	92
ST96420PF	92
STP20L	23, 34
STP30L	23, 34
STP35L	23, 34
STP20R	23, 34
STP30R	23, 34
STP35R	23, 34

T

TG-40	88
TG-60	88

W

W621303N	60
WK241012	56-57, 61-63, 65-74
WW-6	60

0 ~ 9

12442	81
20002	82
3352	2, 69, 70
9646N	3, 43

CONVERSION

Inch to millimeter A	
1 "	25.400 mm
2 "	50.800 "
3 "	76.200 "
1/2 "	12.700 "
1/4 "	6.350 "
3/4 "	19.050 "
1/8 "	3.175 "
3/8 "	9.525 "
5/8 "	15.875 "
7/8 "	22.225 "
1/16 "	1.588 "
3/16 "	4.763 "
5/16 "	7.938 "
7/16 "	11.113 "
9/16 "	14.288 "
11/16 "	17.463 "
13/16 "	20.638 "
15/16 "	23.813 "
1/32 "	0.794 "
3/32 "	2.381 "
5/32 "	3.969 "
7/32 "	5.556 "
9/32 "	7.144 "
11/32 "	8.731 "
13/32 "	10.319 "
15/32 "	11.906 "
17/32 "	13.494 "
19/32 "	15.081 "
21/32 "	16.669 "
23/32 "	18.256 "
25/32 "	19.844 "
27/32 "	21.431 "
29/32 "	23.019 "
31/32 "	24.606 "

1 1/8 "	28.575 mm
1 1/4 "	31.750 "
1 3/8 "	34.925 "
1 1/2 "	38.100 "
1 5/8 "	41.275 "
1 3/4 "	44.450 "
1 7/8 "	47.625 "
2 1/4 "	57.150 "
2 1/2 "	63.500 "
2 3/4 "	69.850 "

Inch to millimeter B	
1/32 "	0.794 mm
1/16 "	1.588 "
3/32 "	2.381 "
1/8 "	3.175 "
5/32 "	3.969 "
3/16 "	4.763 "
7/32 "	5.556 "
1/4 "	6.350 "
9/32 "	7.144 "
5/16 "	7.938 "
11/32 "	8.731 "
3/8 "	9.525 "
13/32 "	10.319 "
7/16 "	11.113 "
15/32 "	11.906 "
1/2 "	12.700 "
17/32 "	13.494 "
9/16 "	14.288 "
19/32 "	15.081 "
5/8 "	15.875 "
21/32 "	16.669 "
11/16 "	17.463 "
23/32 "	18.256 "
3/4 "	19.050 "
25/32 "	19.844 "
13/16 "	20.638 "
27/32 "	21.431 "
7/8 "	22.225 "
29/32 "	23.019 "
15/16 "	23.813 "
31/32 "	24.606 "

1 "	25.400 "
1/8 "	28.575 "
1/4 "	31.750 "
3/8 "	34.925 "
1/2 "	38.100 "
5/8 "	41.275 "
3/4 "	44.450 "
7/8 "	47.625 "
2 "	50.800 "
1/4 "	57.150 "
1/2 "	63.500 "
3/4 "	69.850 "
3 "	76.200 "

millimeter to Inch	
0.2 mm	1/128" (0.198mm)
0.4 "	1/64" (0.397 "
0.6 "	3/128" (0.595 "
0.8 "	1/32" (0.794 "
1.0 "	5/128" (0.992 "
1.5 "	1/16" (1.588 "
2.0 "	5/64" (1.984 "
2.5 "	3/32" (2.381 "
3.0 "	1/8" (3.175 "
3.5 "	9/64" (3.572 "
4.0 "	5/32" (3.969 "
4.5 "	11/64" (4.366 "
5.0 "	13/64" (5.159 "
5.5 "	7/32" (5.556 "
6.0 "	15/64" (5.953 "
6.5 "	1/4" (6.350 "
7.0 "	9/32" (7.144 "
7.5 "	19/64" (7.541 "
8.0 "	5/16" (7.938 "
8.5 "	21/64" (8.334 "
9.0 "	23/64" (9.128 "
9.5 "	3/8" (9.525 "
10.0 "	25/64" (9.922 "
11.0 "	7/16" (10.113 "
12.0 "	15/32" (10.906 "
13.0 "	1/2" (12.700 "
14.0 "	9/16" (14.288 "
15.0 "	19/32" (15.081 "
16.0 "	5/8" (15.875 "
17.0 "	21/32" (16.669 "
18.0 "	23/32" (18.256 "
19.0 "	3/4" (19.050 "
20.0 "	25/32" (19.844 "
22.0 "	7/8" (22.225 "
24.0 "	15/16" (23.813 "
26.0 "	1 "
28.0 "	1 3/32" (27.781 "
30.0 "	1 3/16" (30.163 "
32.0 "	1 1/4" (31.750 "
34.0 "	1 11/32" (34.131 "
36.0 "	1 13/32" (35.719 "
38.0 "	1 1/2" (38.100 "
40.0 "	1 9/16" (39.688 "
45.0 "	1 25/32" (45.244 "
50.0 "	1 31/32" (50.006 "

NOTES

- The content of information like binders, folders, hemmers and fellers trim size on each page is might different with in reality individual specificity. Please use as a measure of size.
- The content products are organized by category, although it is possibility overlapping information more than one category.
- The content of the catalog might use our own description.
- The content products of the catalog modify the design without notice.
- The content products of the catalog diccontinued the production and sale without notice.
- The contents of the catalog modify the design for improvement without notice.
- Although we make assurance doubly sure on accuracy of the information in the catalog, it may contain in accuracies or typos for technical reasons.
- Unauthorized copying and replication of the contents of the illustration, text, images are strictly prohibited.
All rights reserved. Reproducing all or any part of the contents of catalog is prohibited without author' s permission.
- The contents are current as of April 13th, 2018.

"SUISEI" is the registered trademark of TOHKI Industrial Co., Ltd. in the United States and other countries/regions.

"CONCEAL" is the registered trademark of YKK Corporation in the United States and other countries/regions.

SUISEI

Attachments Catalog for Industrial Sewing Machine

PDF E Edition 1.1

Printed in Japan

Author TETSUYA KAWATA
Editor TETSUYA KAWATA
Designer TETSUYA KAWATA
Publication office TOHKI INDUSTRIAL CO., LTD.

SUISEI[®]
OSAKA JAPAN

TOHKI Industrial Co., Ltd.

110-1, Higashi-Handa, Sakai-City, Naka-ku, Osaka, 599-8275 Japan

Phone : (81-72) 270-9115 FAX : (81-72) 270-9600

susei-tohki@tohki-ind.co.jp www.tohki-ind.co.jp